



**MIRA HDR Field Trailer
User Guide**

Our Thanks...

Thank you for choosing Guideline Geo and MALÅ! The very core of our philosophy is to provide our users with great products, support, and services. Our team is committed to providing you with the most efficient and easy-to-use solutions with the capability to meet your needs for efficiency and productivity.

Whether this is your first MALÅ product, or addition to the MALÅ collection, we believe that small investment of your time to familiarize yourself with the product by reading this manual will be rewarded with a significant increase in productivity and satisfaction.

Please let us know about your use and experience of our products as well as the contents and usefulness of this manual. We're excited to be part of your journey!

Under the copyright laws, this manual may not be copied, in whole or in part, without the written consent of Guideline Geo. Your rights to the software are governed by the accompanying software license agreement. The MALÅ logo is a trademark of Guideline Geo registered in Sweden and other countries.

The product described in this document is subject to continuous developments and improvements. All particulars of the product and its use contained in this document are given by Guideline Geo in good faith. However, all warranties implied or expressed, including but not limited to implied warranties or merchantability, or fitness for purpose, are excluded. This document is intended only to assist the reader in the use of the product, and every effort has been made to ensure that the information in this manual is accurate. Guideline Geo shall not be liable for any loss or damage arising from the use of any information in this document, or any error or omission of such information, or any incorrect use of the product. The operation, and interpretations made based on the use of this product is the sole responsibility of the operator.

Guideline Geo, the MALÅ logo, are trademarks of Guideline Geo, registered in Sweden and other countries. Other company and product names mentioned herein are trademarks of their respective companies. The mention of third-party products is for informational purposes only and constitutes neither an endorsement nor a recommendation. Guideline Geo assumes no responsibility with regard to the performance or use of these products.

Guideline Geo AB

www.guidelinegeo.com

Table of content

Mira HDR Field Trailer.....	5
Assembly.....	6
MIRA HDR Field Trailer.....	6
Towing arm.....	7
Wheel hub.....	8
Skid plate.....	9
GNSS frame.....	10
Fitting the MIRA HDR system.....	11
Cables and connections.....	13
Use and adjustments.....	14
Use of remote control.....	14
Adjust the measurement height.....	14
GNSS.....	16
Wheel encoder.....	17
Software.....	17
Skid plate replacement.....	18
Parts included.....	18
Tools needed.....	18
Replacement steps.....	18

MIRA HDR Field Trailer

MIRA HDR Field Trailer is a carrier solution for the MALÅ MIRA HDR multichannel GPR system. This trailer is intended to be used behind an ATV (4-wheeler) or a car, when carrying out e.g., measurements on agricultural land or grass fields.

On roads the speed limitation of the MIRA HDR Field Trailer (when the antenna box is as its highest position) is 50 km/h (31 mph).

Note: It is the user's responsibility to check what road regulations apply in the investigation area and during transport.



Assembly

MIRA HDR Field Trailer

The trailer consists of a main frame (1), towing arm (2), skid plate assembly (3), two wheel hubs (4) and a GNSS frame (5).

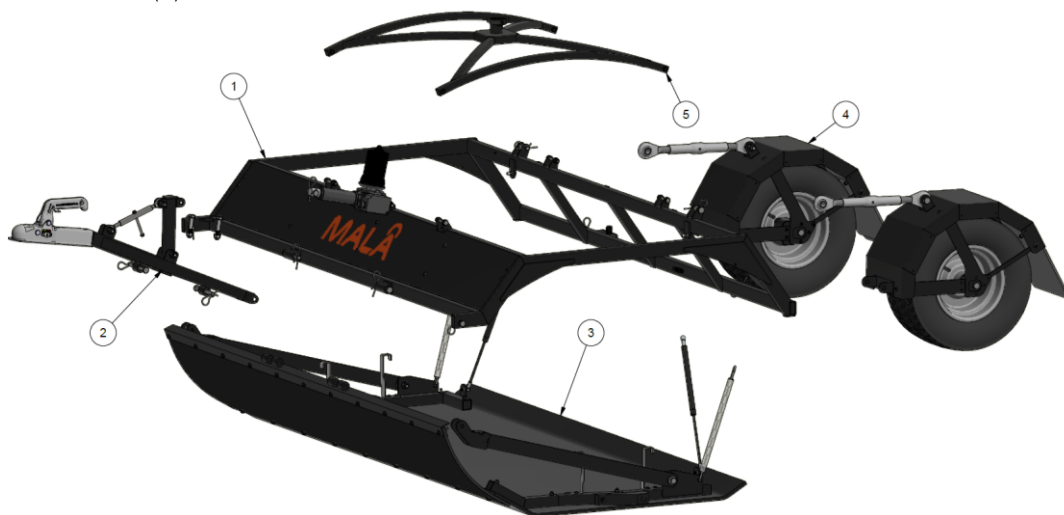

The trailer is delivered in four parts: the towing arm, the frame (main frame with skid plate and GNSS frame in one piece) and the two wheel hubs.



Towing arm

The towing arm is attached to the lower part of the main frame using two clevis pins secured with spring cotter pins.

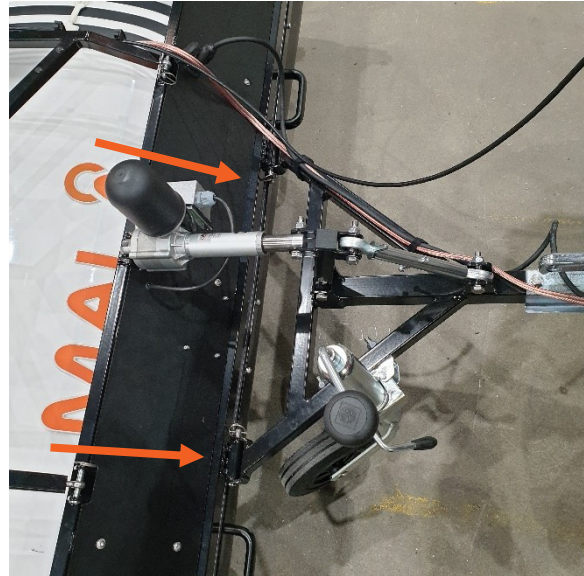

The linear actuator and the adjustable linkage rod are connected to the towing arm top linkage using a bolted connection.



Wheel hub

The wheels attach to the main frame using clevis pins and spring cotter pins, and an adjustable linkage rod.

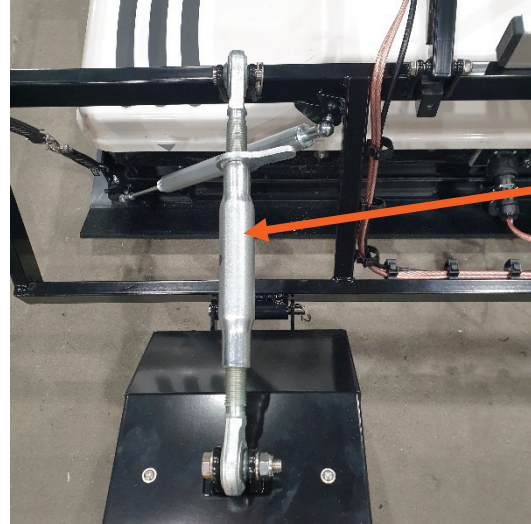

Note: One of the wheels has an integrated wheel encoder. This wheel needs to be placed on the right side of the main frame.

The encoder cable connects to a small black box on the main frame close to the wheel mounting point.

See also section *Adjust the measurement height*, for the use of the adjustable linkage rods.



Skid plate

The skid plate is mounted on delivery.

The rubber front part of the skid assembly is attached under the towing arm (in two places) using clevis pins and spring cotter pins.

The linkage arms on the sides are attached to the two front corners of the main frame, using the same type of attachment.



The gas dampers are attached to the ball joints on the upper and lower part of the main frame. The ball point is pressed to the knob on the main frame.

Note: The gas dampers are attached with the thicker part up.

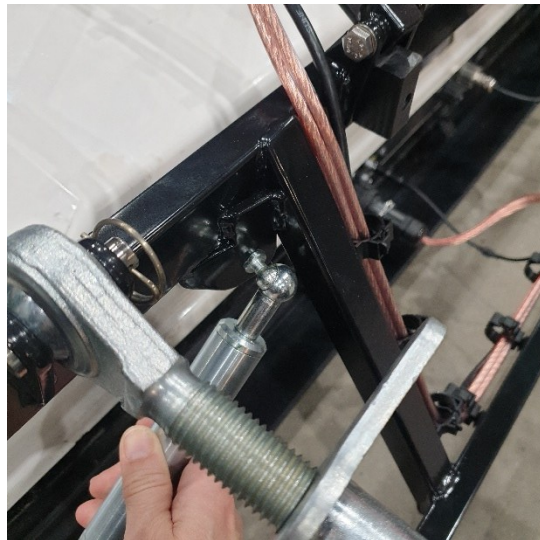

To prevent the gas dampers from overextending a safety band is attached using two shackles.



GNSS frame

The GNSS frame is mounted on delivery.

The GNSS frame is attached to the main frame using bolts and nuts on the rear side, and pin and spring cotter pins on the front side.

Note: If removing the GNSS frame, it is important to use the correct assembly on each side as this enables you to have a quick and easy flip back when mounting the MIRA HDR antenna box.



Front side

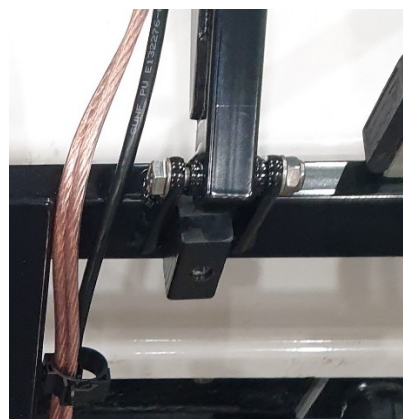

Rear side

Fitting the MIRA HDR system

For efficient mounting of the MIRA HDR system to the MIRA HDR Field Trailer, it is recommended to be two people.

Top loading

1. Release the GNSS frame front pins and flip it backwards to open the main frame.



2. Carefully lift the MIRA HDR system down through the opening, placing it on the skid plate. Make sure it is placed within the frame and all the way down.



3. Secure the MIRA HDR system using the mounting arms, two on each side.



4. Flip the GNSS frame forward and secure the front pins.
5. See section Cables and Connections for connection of needed cables.

Skid plate loading

1. Disassemble the gas damper, the safety bands, the skid plate linkage arms and the skid plate front mounting points.
2. Move the main frame away using the tow-hitch handle to open up the skid plate.
3. Place the MIRA HDR antenna box on the skid plate and secure it using the mounting arms, two on each side. See section Top loading.
4. Roll the main frame back over the skid plate and reassemble all parts removed in Step 1.
5. See section Cables and Connections for connection of needed cables.



Skid plate assembly complete, ready for Step 4.

Cables and connections

Connect the power-, wheel- and Ethernet cable to its corresponding connector on the rear side of the MIRA HDR antenna box.

Note: The Ethernet cable is connected to the right-most connector on the MIRA HDR antenna box.

Make sure the cables are secured to the main frame.

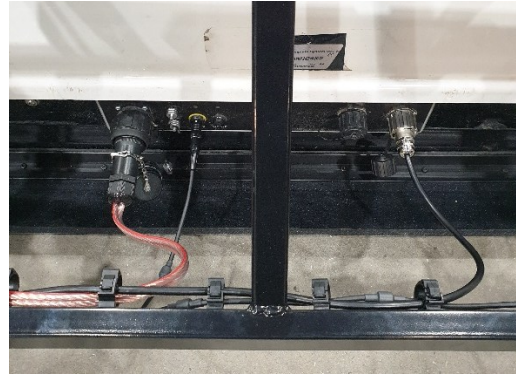

Use and adjustments

Use of remote control

Activate the linear actuator remote by pressing both Up- and Down button and hold for one second.

Note: The linear actuator can also be controlled by the up- and down-buttons on the grey box behind the face plate.

Note: Do not open the grey plastic box mounted at the front side (behind the face plate) of the MIRA HDR Field Trailer. This exposes the relay and controller for the linear actuator, which are not IP rated.

Adjust the measurement height

Preparation

Attach the MIRA HDR Field Trailer to the towing vehicle and find a flat spot. The adjustments are based on the attached vehicle's tow hitch height, so these adjustments need to be repeated when switching vehicle.

Note: If you use a 4-wheeler (ATV) make sure the vehicle is weighed down as in operation before you continue the adjustments to avoid the tow hitch height changing.

Adjust the angle and measurement height

Adjust the MIRA HDR Field Trailer to your vehicle according to the following steps:

1. Adjust the linear actuator to its minimum position using the remote controller.
2. Adjust the front adjustable linkage rod on the towing arm to get the desired measurement height. Lock the adjustment using the locking nut.

Note: Do not adjust beyond 285 mm CC on the front adjustable linkage rod

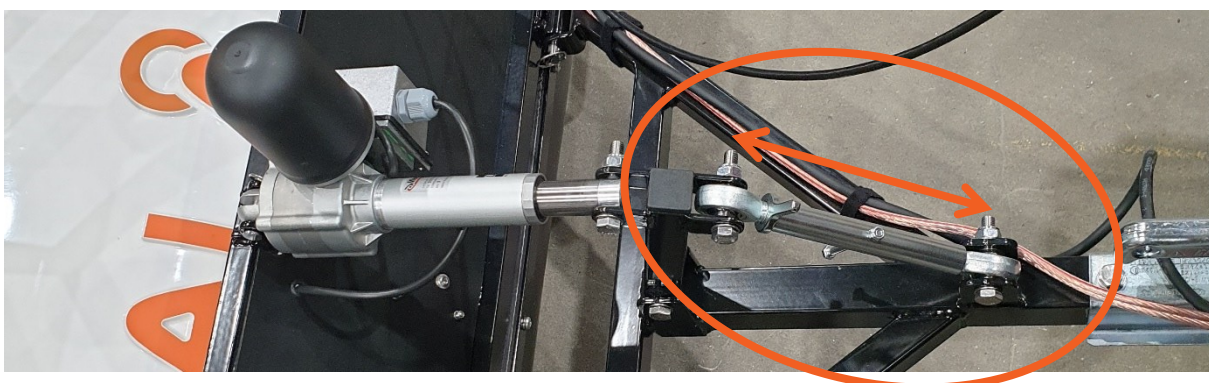

3. Adjust the adjustable linkage rods on the wheel hubs until the main frame is level with the ground (GNSS pole is vertical). Lock the adjustment using the locking nut with handle.

Note: Do not adjust beyond 450 mm CC on the rear adjustable linkage rod

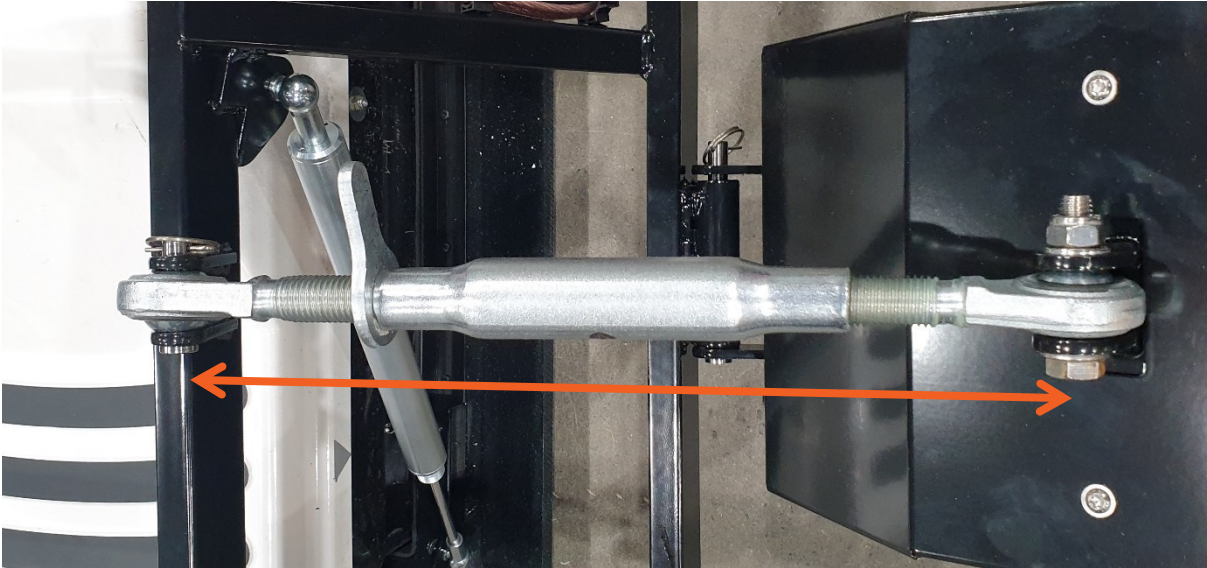

Note: Always secure the locking nuts on the linkage rods firmly.

GNSS

An external GNSS antenna can be attached to the GNSS frame quick release attachment point. A short GNSS pole is provided with the system.

If you need a longer GNSS pole, this together with support arms can be purchased from Guideline Geo. The support arms are mounted on the MIRA HDR Field trailer to ensure the pole rigidity.



GPS support mount



GPS support lower mount



Assembled GPS support

GNSS offset

Use the settings for MALÅ MIRA HDR Field trailer in the GNSS Position drop-down list, in MIRA Controller. The location is X 0.777 and Y 0.19.

Note: Y may vary depending on the height adjustment and angle of the system. Use values based on your own measurements for higher accuracy.

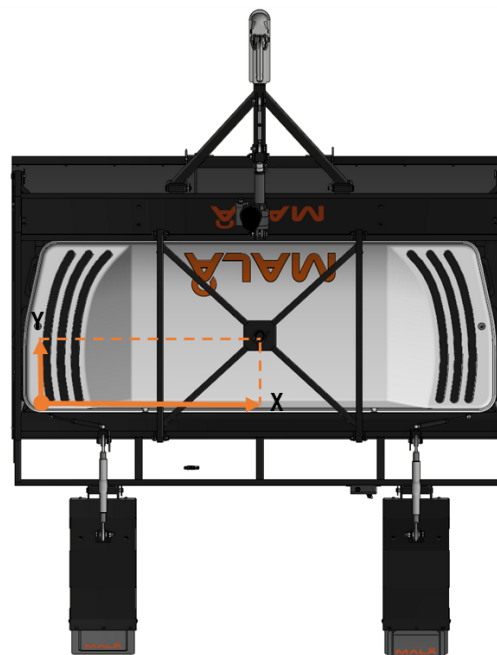

Wheel encoder

The wheel encoder is located on the right tire and is connected to the system through a connection box on the frame.

The provided wheel encoder is available in the encoder drop-down list in the MIRA Controller system. Please refer to the *MALÅ MIRA Controller User Guide*, found at www.guidelinegeo.com for more information

Software

Make sure to always use the latest version of the acquisition software MALÅ MIRA Controller available for download from www.guidelinegeo.com

Skid plate replacement

Parts included

Screws

- 28 pcs – Pan head screws, 5 × 10 mm
- 8 pcs – Countersunk flat head screws, M6 × 50 mm
- 2 pcs – Flat head screws, M6 × 60 mm
- 14 pcs – Flat head screws, M6 × 25 mm

Nuts

- 24 pcs – Hex nuts, M6

Washers

- 24 pcs – Plain washers, 6.4 × 12 × 1.6 mm
- 16 pcs – Plain washers, 6.4 × 18 × 1.6 mm

Tools needed

- TX20 bit
- TX30 bit
- 10 mm wrench or socket

Replacement steps

Step 1 Remove and re-attach angle brackets

1. To get easier access you can start by removing the skid plate assembly from the field trailer. To do this you must remove the 4 pin bolts in the front and detach the dampers and strap linkages in the rear.

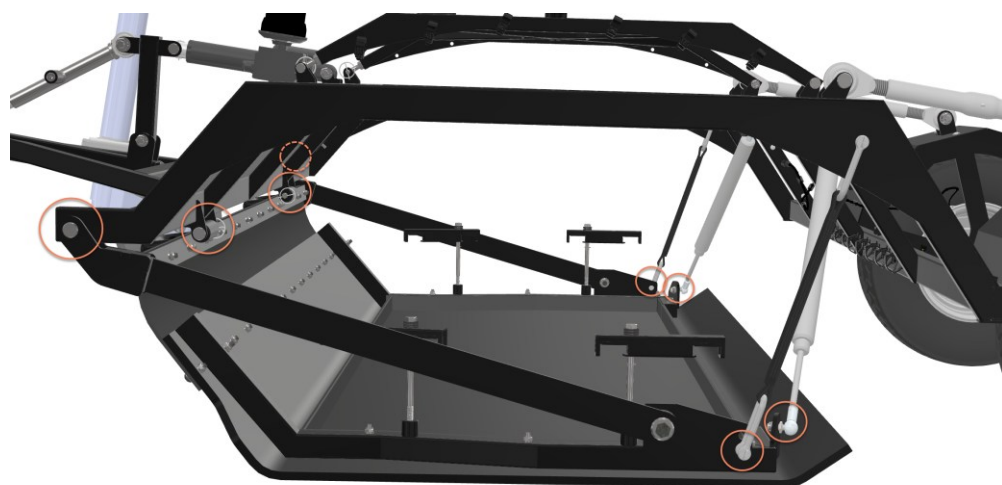

2. Remove the 28 pan head screws (5 × 10 mm) securing the angle brackets to the skid plate.

3. Use a *TX20 bit*.
4. Transfer the angle brackets to the new skid plate.
5. Secure the brackets using *new pan head screws included in the package*.

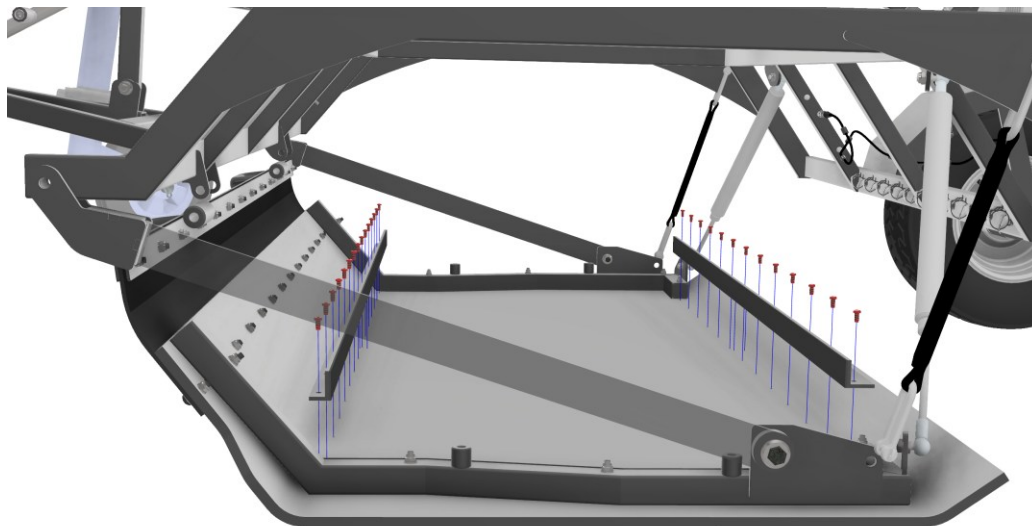

The Angle brackets are removed from the old skid plate and re-attached on the new skid plate with 28 Pan head screws (5x10 mm) with a TX20 bit.

Note: Do not reuse removed screws.

Note: Ensure all brackets are correctly oriented before tightening.

Step 2 Remove screws underneath the skid plate

1. From underneath the skid plate, remove the 8 countersunk flat head screws (M6 × 50 mm).
2. Use a TX30 bit on the screw and a 10 mm wrench on the nut located on the top side.

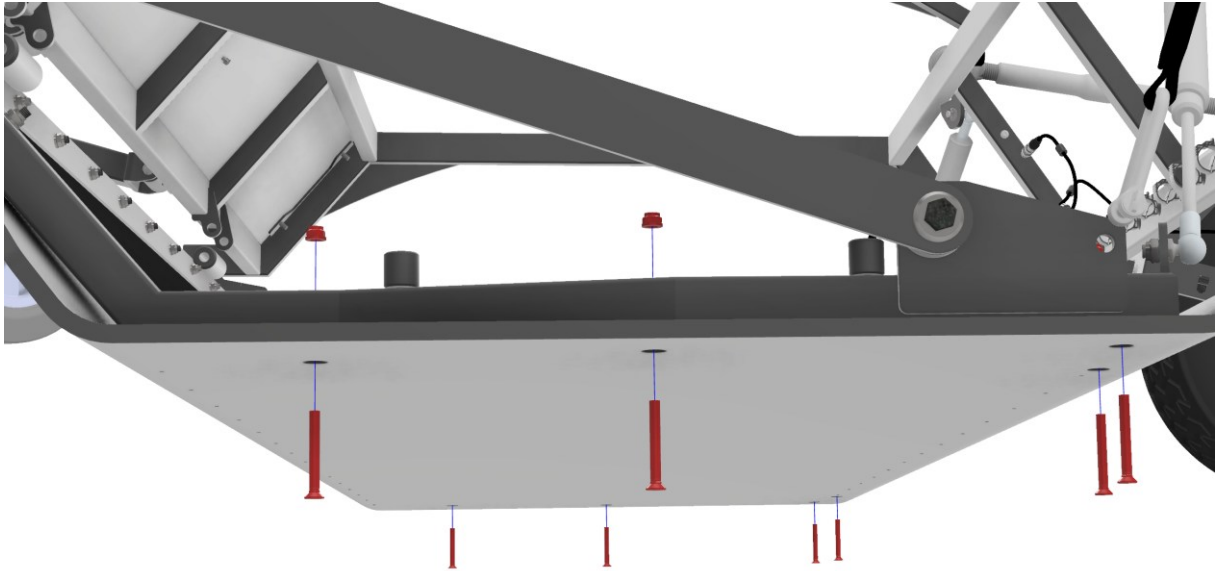

8 countersunk flat head screws (M6 × 50 mm) are removed using a TX30 bit on the screw and a 10 mm wrench on the nut located on the top side.

Step 3 Remove skid plate from rubber mat

1. At the front of the skid plate, remove all fasteners attaching it to the rubber mat.
2. Remove:
 - 2 long flat head screws (M6 × 60 mm)
 - 14 short flat head screws (M6 × 25 mm)
3. Use a *TX30 bit* on the screw and a *10 mm wrench* on the nut.

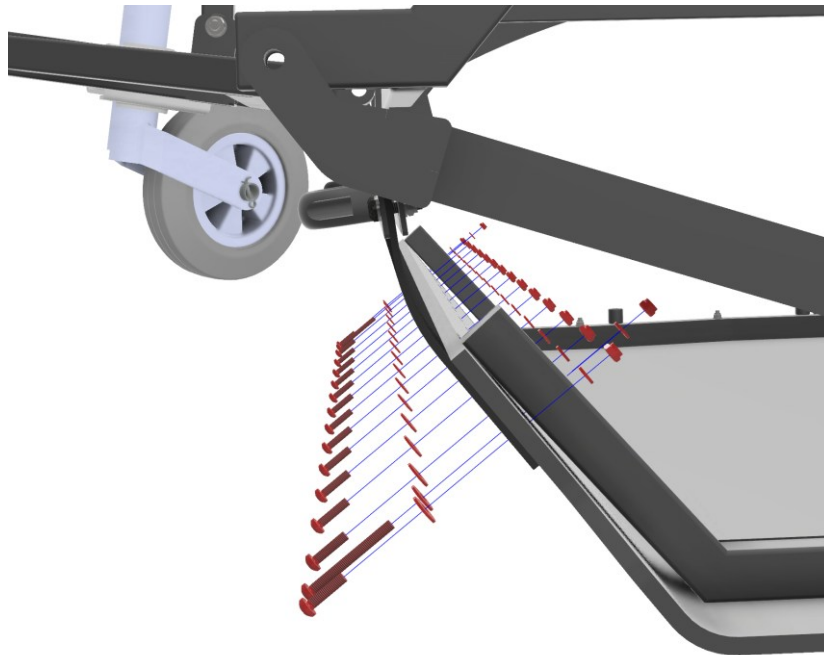

Remove 2 long flat head screws (M6 × 60 mm) and 14 short flat head screws (M6 × 25 mm) including nuts and washers. Use a *TX30 bit* on the screw and a *10 mm wrench* on the nut.

Step 4 – Install New Skid Plate

- Install the new skid plate by following *Steps 3, 2, and 1* in reverse order.
- Use *only new fasteners* included in the package.
- Ensure the *correct screw lengths* are used in the front section. 2 × M6 × 60 mm and 14 × M6 × 25 mm
- Tighten all fasteners securely.

Note: Do not reuse removed fasteners

Note: Verify the skid plate is seated correctly and flush before final tightening

Note: If you encounter issues during installation, contact Guideline Geo support with your trailer serial number.