



**MALÅ MIRA Compact**  
**User Guide**

## Our Thanks...

Thank you for choosing Guideline Geo and MALÅ as your Ground Penetrating Radar solution provider. The core of our corporate philosophy is to provide our users with the best products, support and services. Our development team is committed to providing you with the most technologically advanced and easy-to-use GPR products that can meet your efficiency, and productivity needs now and in the future. Whether this is your first MALÅ product or an addition to the MALÅ collection, we believe that a small investment of your time to familiarize yourself with the product by reading this manual will be rewarded with a significant increase in productivity and satisfaction.

At Guideline Geo, we welcome comments concerning the use and experience with our products and the contents and usefulness of this manual.

Guideline Geo team

Under the copyright laws, this manual may not be copied, in whole or in part, without the written consent of Guideline Geo. Your rights to the software are governed by the accompanying software license agreement. The MALÅ logo is a trademark of Guideline Geo registered in Sweden and other countries.

The product described in this document is subject to continuous developments and improvements. All particulars of the product and its use contained in this document are given by Guideline Geo in good faith. However, all warranties implied or expressed, including but not limited to implied warranties or merchantability, or fitness for purpose, are excluded. This document is intended only to assist the reader in the use of the product, and every effort has been made to ensure that the information in this manual is accurate. Guideline Geo shall not be liable for any loss or damage arising from the use of any information in this document, or any error or omission in such information, or any incorrect use of the product.

Guideline Geo, the MALÅ logo, are trademarks of Guideline Geo, registered in Sweden and other countries. Other company and product names mentioned herein are trademarks of their respective companies. Mention of third-party products is for informational purposes only and constitutes neither an endorsement nor a recommendation. Guideline Geo assumes no responsibility with regards to the performance or use of these third-party products.

Guideline Geo AB

[www.guidelinegeo.com](http://www.guidelinegeo.com)

# Table of Contents

Preface	5
Safety and Compliance User Notices	6
About MIRA Compact	8
Unpack. Inspect. Register	9
Overview MIRA Compact	10
System set-up	11
System components	13
Antenna box	13
Carrier frame	17
Data acquisition software	23
Post-processing software	23
Positioning	24
Maintenance	26
Cleaning	26
Pivot wheel	26
Accessories	28

# Preface

## About this Manual

This manual is written for the end user, explains how to set up and configure the product, and provides detailed instructions on its use.

## Additional Resources

Training: [www.guidelinegeo.com/training-gpr-resistivity-seismics-tem/](http://www.guidelinegeo.com/training-gpr-resistivity-seismics-tem/)

Downloads: [www.guidelinegeo.com/support-service-advice-training/resource-center/](http://www.guidelinegeo.com/support-service-advice-training/resource-center/)

Applications: [www.guidelinegeo.com/application-areas/](http://www.guidelinegeo.com/application-areas/)

## Feedback and Support

Feedback regarding the contents of this manual or the product may be sent using any of the contact details found at [www.guidelinegeo.com](http://www.guidelinegeo.com)

For technical support, please get in touch with [support@guidelinegeo.com](mailto:support@guidelinegeo.com)

# Safety and Compliance User Notices

This GPR device is certified according to FCC, subpart 15, IC RSS-220 and ETSI EN 302 066-1&2.

You are cautioned that changes or modifications not expressly approved by the party responsible for compliance could void the user's authority to operate the equipment.

**Note:** This equipment has been tested and found to comply with the limits for a Class B digital device, pursuant to part 15 of the FCC Rules. These limits are designed to provide reasonable protection against harmful interference in a residential installation. This equipment generates, uses and can radiate radio frequency energy and, if not installed and used in accordance with the instructions, may cause harmful interference to radio communications. However, there is no guarantee that interference will not occur in a particular installation. If this equipment does cause harmful interference to radio or television reception, which can be determined by turning the equipment off and on, the user is encouraged to try to correct the interference by one or more of the following measures: — Reorient or relocate the receiving antenna. — Increase the separation between the equipment and receiver. — Connect the equipment into an outlet on a circuit different from that to which the receiver is connected. — Consult the dealer or an experienced radio/TV technician for help.

## According to the regulations stated in ETSI EN 302 066-1 (European Telecommunication Standards Institute):

The control unit should not be left *ON* when leaving the system unattended. It should always be turned *OFF* when not in use.

The antennas should point towards the ground, walls etc. during measurement and not towards the air.

The antennas should be kept in close proximity to the media under investigation.

## **Canadian and US regulations state that whenever GPR antennas are in use the following notes apply:**

This Ground Penetrating Radar device shall be operated only when in contact with or within 1m of the ground.

Only law enforcement agencies, scientific research institutes, commercial mining companies, construction companies and emergency rescue or firefighting organizations shall use this Ground Penetrating Radar Device.

This device complies with Industry Canada license-exempt RSS standards. Operation is subject to the following two conditions: (1) This device may not cause interference and (2) this device must accept any interference, including interference that may cause undesired operation of the device.

### **French translation**

Cet instrument de Géoradar se devra d'être opéré seulement en contact à même le sol ou en deça d'un mètre du sol.

Cet instrument de Géoradar se devra d'être utilisé seulement par les agences chargées de l'application de la loi, les instituts de recherches scientifiques, les compagnies minières à buts lucratifs, les compagnies de construction et les organisations responsables pour le sauvetage et la lutte contre les incendies.

Cet instrument répond aux exigences de la licence avec Industrie Canada- exempt des standards RSS. L'opération est sujette aux deux conditions suivantes: (1) Cet instrument ne peut pas causer une interférence et (2) Cet instrument se doit d'accepter quelque interférence que ce soit, incluant une interférence qui pourrait causer une opération non-souhaitable de l'instrument.

## **Radiation Exposure Statement**

To comply with ISED and FCC RF exposure compliance requirements, a separation distance of at least 20 cm should be maintained between the EUT and all persons during normal operation.

### **French translation**

Pour se conformer aux exigences de conformité d'exposition ISDE et FCC RF, une distance de séparation d'au moins 20 cm doit être maintenue entre l'EST et toutes les personnes pendant le fonctionnement normal.

## About MIRA Compact

The MIRA Compact and the data acquisition software MIRA Controller are efficient and easy-to-use multi-channel systems for 3D GPR measurements.

The MIRA Compact system enables measurement combinations between any of the individual receiver and transmitter antennas used in the array, and all antennas use the MALÅ HDR technology (High Dynamic Range).

When careful attention is given to accurate positioning and data collection, the MIRA Compact array produces extremely high-resolution output. As a standard, you measure ten channels with only a 6.5 cm separation.



# Unpack. Inspect. Register

Great care should be taken when unpacking the equipment. Be sure to verify the contents in the packing list and inspect the equipment and accessories for any loose parts or other damage.

**Note:** The packing list that is included with the shipment should be read carefully and any discrepancy should be reported to our sales department at [www.guidelinegeo.com](http://www.guidelinegeo.com)

**Note:** All packing material should be kept if any damage occurred during shipping.

File any claim for shipping damage with the carrier immediately after discovering the damage and before the equipment is used. Any missing equipment or parts claims should be filed with Guideline Geo within fourteen (14) business days of receiving the equipment.

## Repacking and Shipping

The Guideline Geo wooden freight crate is specially designed to ship the MIRA Compact. This crate should be used whenever shipping is necessary. If original packing materials are unavailable, pack the instrument in a large box to allow at least 80 mm of shock-absorbing material to be placed all around the instrument. This includes the top, bottom and all sides.

**Warning:** Never use shredded fibres, paper, or wood wool, as these materials tend to compress and permit the instrument to move inside packing box.

Please read our shipping instructions before returning instruments to Guideline Geo. These instructions can be found on our website at [www.guidelinegeo.com](http://www.guidelinegeo.com). Click on Support.

## Registering your MIRA Compact

By registering your equipment, you ensure that you will receive important information, such as manual updates, software upgrades and other product information, which helps optimise the equipment's utilisation and realize the maximum return on your investment.

To register your equipment, visit [www.guidelinegeo.com](http://www.guidelinegeo.com) and click on Support.

**Note:** The serial number is found on the rear right-hand side of the antenna box.

## Overview MIRA Compact

In short, the MIRA Compact system comprises the following parts:

- MIRA Compact antenna box. A special antenna box for deploying the MIRA Compact system holds six receiver (Rx) and five transmitter (Tx) antennas with a central frequency of 500 MHz. The default setup provides a 10-channel swath; however, it is possible to program any Tx-Rx combination, giving up to 30 data channels. Four hot-swappable internal batteries power the antenna box.
- MIRA Compact carrier frame. The carrier has three wheels, a handle, a computer holder, a GNSS mount and two integrated encoders on the rear wheels. The encoders are used to trigger data collection and keep track of the distances.

To make the system complete and ready for measurement, the following are also needed:

- Field computer (Windows 10 or later with Ethernet port) with the MIRA Controller software installed to collect, save and view multi-channel data. We strongly recommend the use of a rugged field computer.
- Positioning system, e.g. RTK-GNSS or Total station.



To connect the parts, see the *System Setup* section below. Instructions and information for carrying out a multi-channel MIRA measurement can be found in the *MIRA Controller User Guide*.

## System Setup

1. Connect the Ethernet cable between the computer with the MIRA Controller installed and the connector marked Ethernet on the connector panel of the antenna box. See section *Antenna box*.
2. Make sure that the encoder cable is connected between the MIRA Compact carrier frame and the Encoder connector on the connector panel of the antenna box. See section *Antenna box*.
3. Mount the GNSS antenna, and if using an RS-232 cable for your GNSS, connect it to your computer. See section *Positioning*.
4. If you need to power your computer, connect the same to the Power Out connector (USB-C) on the connector panel. See section *Antenna box*.
5. Power up the MIRA Compact and wait for the light on the On/Off button to change from blinking to solid (the hardware is ready to connect to the MIRA Controller). See section *Antenna box*.
6. Start the MIRA Controller software on your computer. The system will automatically connect, and the software will guide you through all the necessary steps. See section *Data acquisition software*.
7. See the *MIRA Controller User guide* for details on how to operate the software.

**Note:** When cables are not connected, the protective caps of the connectors **MUST** be attached. This prevents dirt and moisture ingress in the connectors.

## Swath width and center of the antenna

The MIRA Compact antenna box, with marking of swath width (arrow) and centre point (dashed line). The swath width and the centre point are also marked on the carrier frame.



# System components

## Antenna box

### Antennas

The MIRA Compact antenna box is available with a centre frequency of 500 MHz. This frequency will cover investigation depths down to approximately 4-5 meters. The maximum measurement depth will vary and depends, for example, on the soil conductivity locally.

The MIRA Compact antenna box houses five transmitters and six receivers.

### Connector panel

All connectors are placed at the rear side of the antenna box. Here, from left to right, you find the connection to the encoders, antenna connector to the internal GNSS<sup>1</sup>, Power In for charging, charge indicator, On/Off button, Power Out (USB-C) and Ethernet connection. Also, see the *System Setup* section.

When powered, the On/Off button diode blinks while the MIRA Compact system is booting; it becomes solid once it is ready to connect to the MIRA Controller.



**Note:** When cables are not connected, the protective caps of the connectors MUST be attached. This prevents dirt and moisture ingress in the connectors.

### Cables

An Ethernet and a USB-C cable are supplied with the system. The Ethernet cable for data transfer has a rugged connector on the antenna side for reliable and robust data collection.

The USB-C cable connects to the Power Out connector and can charge a laptop or other peripheral units, e.g., an RTK GNSS. Any USB-C cable can be used; however, it is strongly recommended to use the supplied cable since it protects the connector on the antenna box.

Spare cables can be purchased directly from Guideline Geo or your local MALÅ partner.

---

<sup>1</sup>The *Ext. Antenna* connector is intended for future features.

### Built-in GNSS

The MIRA Compact has a built-in GNSS module that utilises the Pulses Per Second (PPS) output to synchronise the recorded traces with the external RTK GNSS measurement input. This aids in an improved positioning and alignment of each recorded trace due to potential latency between the external GNSS and the MIRA Compact.

A GNSS antenna is located inside the antenna box. If the system is covered or placed in surroundings where satellite view is blocked, the GNSS reception can be too poor for the system to get a time lock. Move the system to a position with better satellite reception to get a time lock before beginning your measurements.

### Batteries

Four 14.4V Li-Ion batteries power the MIRA Compact. The batteries are in the battery compartment behind the two black lids. Ensure the lids are securely closed to prevent water and dust from entering.

The batteries are hot-swappable, meaning that batteries can be exchanged while the system is running as long as at least one charged battery is kept in the system. The system can be used with a single battery if needed. However, we recommend always using four batteries for optimal survey time and performance.

**Note:** Power off the antenna array when not in use to prevent battery drainage.

All four batteries can be charged in the system using the provided charger. Connect the charger to the Power In connector on the antenna box connector panel. MIRA Compact does not have to be powered on to charge batteries. The red charge indicator LED on the system will be lit while the batteries are charging and shut off when charging is complete.



The green indicator on the charger is lit whenever the charger is powered and does not indicate the charge state.

When the charger is connected to the system, the USB-C connector will also provide power, enabling you to charge a laptop simultaneously.

**Note:** The charge indicator LED on the system only indicates charging the internal batteries, not devices being charged via the USB-C connector. Always check the charge and power status on your peripheral devices separately.

The batteries can also be charged in the external intelligent battery charger, where two batteries can be charged at the same time.



Powering the MIRA Compact batteries with the external charger is done as follows.

Powering the charger:

1. Connect all cables to the charger and plug it into the mains socket.
2. The LED will turn off once the battery charger completes its self-test. The battery charger is now ready for use.
3. If the red control lamp stays on without a battery in the charger, the charger is defective.

Charging batteries:

1. Connect the battery charger as described above.
2. Place a discharged Smart Battery into the battery charger.
3. The battery charger makes battery recognition and initialization.
4. The battery will be charged; leave the battery until the green LED lights.
5. Remove the battery for use.

The LED light on the external charger indicates the following cycles.

One time Red/Orange/Green	Self-test: Charger is ready for use
Red/Green blinking	The battery is not recognised as a Smart Battery. Either a conventional battery is inserted or an excessively discharged Smart Battery. If it is a Smart Battery, it will be reactivated within 15 minutes and recharged. If this is not the case, the LED will light red – see below.
Orange blinking	The battery is currently being calibrated.
Orange light	The inserted battery is the correct type and is currently being charged.
Green light	The battery is charged and can be removed for use.
Red blinking	The battery is too hot or too cold to be charged without damage. If the battery is too cold, it will be charged as soon as it has warmed up sufficiently. If the battery is too hot, it should be removed to cool down.
Red light	Either the battery is damaged and must be replaced, or it is a conventional battery that cannot be recharged.

## Skid plate

The skid plate is attached directly to the antenna box. It is intended to protect the bottom of the antenna box. It is sealed to the antenna box to prevent water from collecting under the antenna box, potentially affecting the data. The skid plate is expected to be worn out and changed when needed. How often depends on how the system is used, including ground conditions. We recommend inspecting the skid plate before and after each use. New skid plates can be purchased directly from Guideline Geo or your local MALÅ partner.

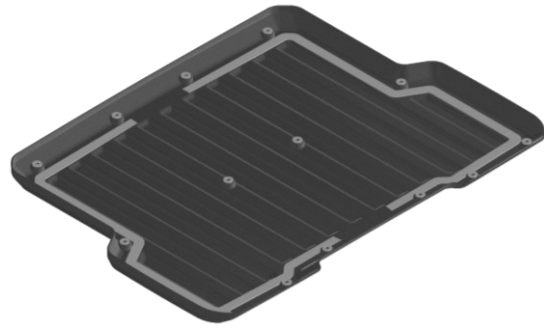

**Note:** The skid plate is expected to be worn out and changed when needed.

To replace the MIRA Compact skid plate, follow these steps:

- Remove the screws with a TX25 screwdriver. There are 14 screws in total.
- Remove the skid plate.
- Mount the new skid plate and fasten it using the new screws supplied.

It is possible to replace the skid plate while it is mounted on the carrier frame.

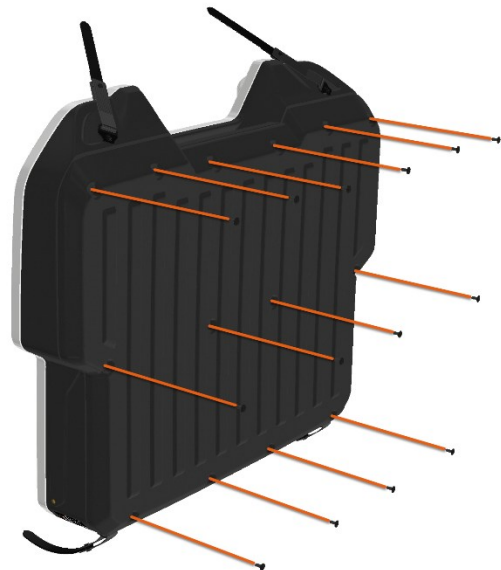

*The antenna box with skid plate and screws*

The skid plate is made of High-Density Polyethylene (HDPE) and should be recycled according to local recycling guidelines. There is a stamped mark with a recycling symbol on the inside of the skid plate stating that it's made of recyclable material, code 2 (HDPE).

## Straps

Pull the height-adjusting lever (1) on each strap to the desired height to adjust the ground clearance. To lower the antenna, pull distinct on the release levers (2). If there are difficulties lowering the antenna, lift the antenna with one hand while pulling the release lever.

The straps can easily be replaced if needed due to wear and tear. New straps can be purchased directly from Guideline Geo or your local MALÅ partner.

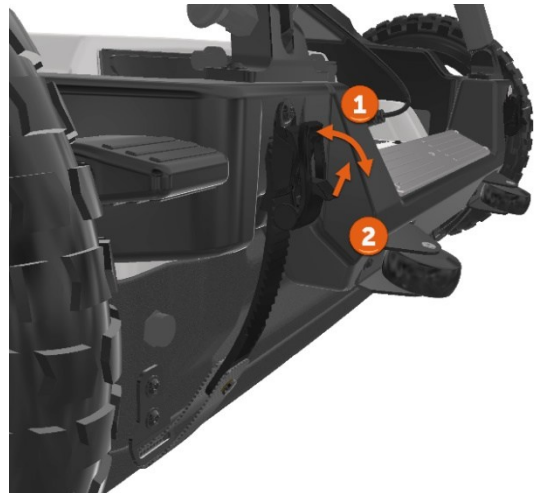

## Carrier frame

### Antenna assembly

The antenna is mounted in the carrier frame using four straps and two stabilizer arms. The floating antenna solution makes it possible to operate MIRA Compact over uneven surfaces. The ground clearance is easily adjusted using the straps.

**Note:** Disconnect all cables before detaching the antenna box from the carrier frame.

To detach the antenna from the carrier frame, start by detaching the four straps, then tilting the carrier frame backwards. You can access and unscrew the two shoulder screws with a 4 mm hex key.



### Fully foldable handle

Before folding the handle and not risk stretching the cables, ensure the white markings align with the white Flie-tie cable fastener on the handle.

To fold handle on frame:

- Begin by unlocking the lower plungers.
- Raise the support arms.
- Pull the dog bone sleeve and fold down the upper handle.
- Fold the handle forward.
- Push down the handle to secure it to the frame plungers.

When unfolding the handle, follow the reverse order of the steps. Be cautious not to pinch any cables while folding or unfolding the handle.

Align the white markings on the cables to the white cable holder on the handle to ensure enough slack on the cables to fold the handle.

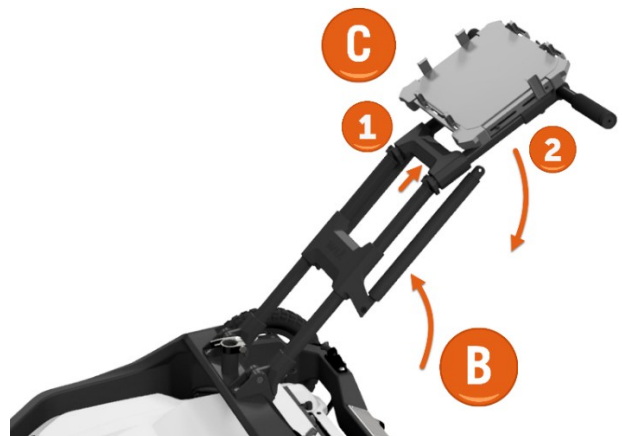
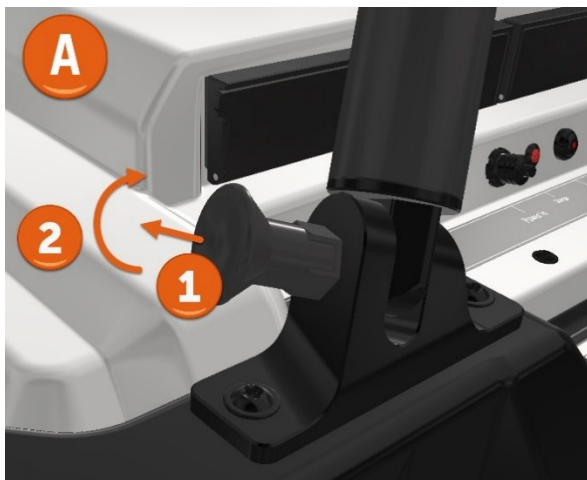



### Laptop holder

Adjust the angle of the laptop holder by pulling the MALÅ lanyard and setting it to a preferred angle. See the separate guide for first-time adjustment of the laptop holder to fit your field laptop.



**Note:** Use the arm on the computer holder to support the computer screen for secure measurement on rougher terrain.

## Brakes

The MIRA Compact has foot-operated brakes for the two rear wheels. Push the paddle down to engage the brake and lift to release it. Make sure the brakes are released before moving the unit.



## Encoders

The system has two encoders, one on each rear wheel. A single cable and connector (on the upper frame's left side) transfer the signals from both encoders to the antenna box. Should there be any issues with an encoder, it is possible to configure the system to use either the right or left encoder instead of both. This is done using the MIRA Controller software.

MIRA Controller includes default encoder values (*Compact Frame*). For accurate triggering, we recommend calibrating the wheels regularly. See the *MALÅ MIRA Controller* user guide for more information.

## Pivot wheel

The carrier frame has a pivot wheel at the front for easy manoeuvring. This can be locked to a straight position using the lock pin. Pull the pin upward to release and rotate a quarter of a turn. To lock, ensure the wheel is straight, then rotate the pin a quarter of a turn, and it will slide into position to lock the wheel.



### Transport wheels

Moving the MIRA Compact system through narrow passages using the transport wheels is easy. The MIRA Compact frame has two wheels for easy transportation. You fold the handle, raise the system on the rear side, secure the handle with the included strap around the handle and frame and then move the system as a suitcase.

**Note:** Make sure the cables are mounted with some slack before folding the handle. The white mark on the cables should match the white Flie-tie cable fastener on the handle.



### GNSS and prism pole mount

The carrier frame has a quick-release GNSS and prism pole connection (1) designed for 25 mm diameter poles. An adapter (2) with 5/8 UNC threading is included if you have a thicker pole.

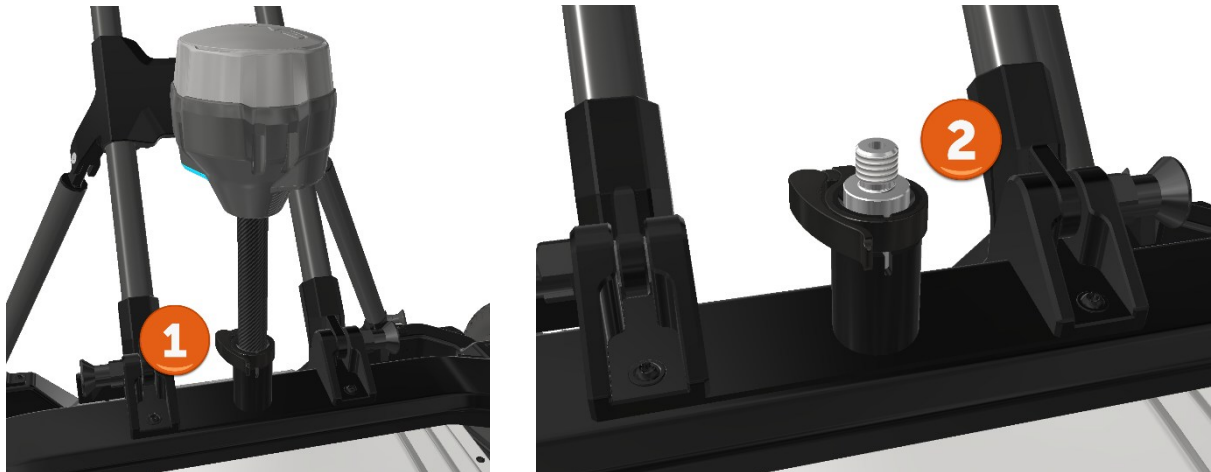

MIRA Compact comes with a 150 mm long GNSS pole as standard. If you require a longer pole, we recommend the MALÅ GNSS support kit, which includes an 800 mm pole. This kit is available directly from Guideline Geo or your local MALÅ partner.

**Note:** The MALÅ GNSS support is designed for use with 25 mm diameter poles only.



## Data acquisition software

The MIRA Controller data acquisition software simplifies collecting, viewing, and saving data from the MIRA Compact.

This user-friendly software offers a straightforward application. For more details, refer to the *MIRA Controller User Guide*.

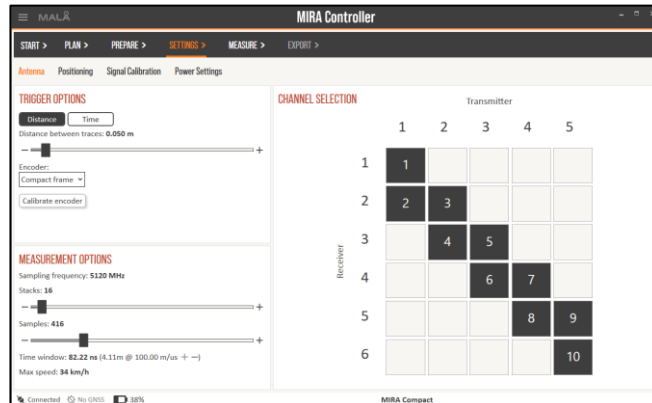

The computer used for measurements should be placed conveniently for the operator to monitor the measurement progress while investigating.

**Note:** It is strongly recommended that you use a laptop with a native Ethernet port. The use of Ethernet adapters may cause unexpected issues during data collection.

The MIRA Controller software aids data collection with a satisfactory overlap between swaths and will provide information on the coverage of your investigation area.

## Post-processing software

Data from MIRA Compact and MIRA Controller measurements can efficiently be post-processed in the MALÅ Vision Desktop software. For more information, see the *MALÅ Vision Desktop User Guide*.

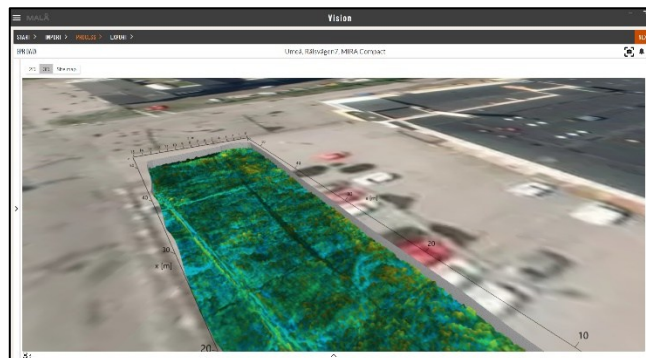

# Positioning

For an accurate 3D radar picture, precise positioning of the antenna array is crucial throughout the survey. Achieving centimetre accuracy across the entire investigation site is essential. The MIRA Compact offers flexibility in positioning, supporting both RTK GNSS and Total station solutions.

The GNSS system can function as a rover-base setup or without a base station, provided a compatible rover unit and correction subscription service are available.

**Note:** Ensure the base is correctly positioned when using a base-rover setup.

Configure the positioning system to export data in NMEA 0183 GGA format for the GNSS option, allowing the MIRA Controller data acquisition software to record and assign it to the GPR swaths accurately.

For hand-pushed measurements, it's recommended to use a GNSS update rate of 5 Hz.

The GNSS antenna or the Total Station prism can be attached to the MIRA Compact Carrier solution, supplemented with the MALÅ GNSS support, see section *GNSS and Prism pole mount*.

Choosing the positioning method depends on the investigation site conditions:

- In environments with trees, high buildings, or other obstacles, a Total Station is preferred.
- However, on open ground with lower vegetation and/or fewer overhead obstacles, an RTK GNSS solution is often a faster and easier positioning method.
- The Total Station needs a line of sight and possibly an extra operator for the Total Station if tracking fails.
- If the investigation area is large, the Total Station may need to be moved and new Total Station positions defined, which can be more time-consuming. However, a Total Station can cover every type of investigation area, which is not the case with a GNSS.

**Note:** Temporary loss of tracking will not cause the data to be useless, provided each swath's start and end points are well defined.

**Note:** Measurements can be carried out without any positioning system but are only generally recommended if necessary. The measurement lines should be straight and have an even spacing so coordinate files for post-processing software can be created afterwards.

# Transportation

When transporting the MIRA Compact on a truck bed or with a trailer, store the MIRA Compact in the wooden shipping crate where the equipment was delivered.

If this is not possible, take the following actions for safe transportation:

- Remove the laptop.
- Fold down the handle. For more information, see the section on the *Fully foldable handle*.
- Make sure the brakes are on. For more information, see section *Brakes*.
- Lower the antenna box by adjusting the straps so it is standing on the vehicle's floor; see section *Straps*.
- Secure the MIRA Compact with additional straps to ensure it cannot move when turning or braking.

**Note:** When transporting the MIRA Compact in a car, follow the steps above for safe transportation.

If the MIRA Compact needs to be transported by a shipping company, see the information in the *Repacking and Shipping* section.

# Maintenance

## Cleaning

To keep your MIRA Compact in top condition, follow these simple cleaning steps:

- Gently wipe the MIRA Compact with a wet towel containing mild soap.
- If needed, you can use a water hose for rinsing. Ensure battery compartments are securely closed.
- Dry off any excess water with a towel and allow it to air-dry thoroughly before using it again.

**Warning:** Do NOT use a pressure washer to clean the MIRA Compact.

**Warning:** Do not use any strong cleaning chemicals when cleaning the MIRA Compact.

## Pivot wheel

**Note:** This section is valid ONLY for MALÅ MIRA Compact units manufactured before November 2025.

If you encounter any issues with the pivot wheel, follow these steps:

### 1. Detaching the pivot wheel

Press the push button (1) while lowering the pivot wheel (2) to detach it.



## 2. Cleaning and maintenance

Ensure the axle and bronze bushing in the frame are clean and free from dirt or debris.

For additional access, remove the top cover by taking out the two screws on top.

Every 6 months, spray the axle and bushing with WD40, and wipe with a clean cloth to remove any dirt or moisture. Then apply silicon-based oil to the axle and bushing and re-attach the pivot wheel (see instruction below).

## 3. Re-attach the pivot wheel

Make sure to press the pivot wheel axel upward until the axel button is released.



## Accessories

To enhance efficiency during fieldwork, we offer a range of accessories:

- Rugged field computer
- GNSS antennas
- Tripod for base GNSS antenna
- Different length GNSS poles
- Extra batteries and chargers
- Extra skid plates
- Spare cables (Ethernet, USB-C, Encoder)

Feel free to explore these accessories to tailor your equipment to specific needs. If you have any questions or need assistance, don't hesitate to contact Guideline Geo or your local MALÅ partner.