



MALÅ Ground Explorer GX
User Guide

Our Thanks...

Thank you for choosing Guideline Geo and MALÅ as your Ground Penetrating Radar solution provider. The very core of our corporate philosophy is to provide our users with the very best products, support and services. Our development team is committed to providing you with the most technologically advanced and easy-to-use GPR products with the capability to meet your needs for efficiency and productivity now, and into the future.

Whether this is your first MALÅ product, or an addition to the MALÅ collection, we believe that a small investment of your time, to familiarize yourself with the product by reading this manual, will be rewarded with a significant increase in productivity and satisfaction.

At Guideline Geo, we welcome comments concerning the use and experience with our products, as well as the contents and usefulness of this manual.

Guideline Geo team

Under the copyright laws, this manual may not be copied, in whole or in part, without the written consent of Guideline Geo. Your rights to the software are governed by the accompanying software license agreement. The MALÅ logo is a trademark of Guideline Geo registered in Sweden and other countries.

The product described in this document is subject to continuous developments and improvements. All particulars of the product and its use contained in this document are given by Guideline Geo in good faith. However, all warranties implied or expressed, including but not limited to implied warranties or merchantability, or fitness for purpose, are excluded. This document is intended only to assist the reader in the use of the product and every effort has been made to ensure that the information in this manual is accurate. Guideline Geo shall not be liable for any loss or damage arising from the use of any information in this document, or any error or omission in such information, or any incorrect use of the product.

Guideline Geo, the MALÅ logo, are trademarks of Guideline Geo, registered in Sweden and other countries. Other company and product names mentioned herein are trademarks of their respective companies. Mention of third-party products is for informational purposes only and constitutes neither an endorsement nor a recommendation. Guideline Geo assumes no responsibility with regard to the performance or use of these products.

Guideline Geo AB

www.guidelinegeo.com

Table of Contents

Preface	5
Get Ready. Set up. Go	6
Accessories	7
Unpack. Inspect. Register	8
Repacking and Shipping	8
Registering MALÅ GX HDR	8
System set up	9
Connecting it all up	10
Power up	10
Power down	10
Power and Charging	11
User Interface	12
Start Menu	12
Navigating the Menus and Options	13
Main 2D Project Menu	13
Zoom Function	14
Main Menu Icons	15
Measurement Parameters Menu	17
Acquisition Parameters Menu	19
Wheels Edit and Calibration Menu	20
Wheels Edit Options	21
Display Parameters Menu	22
Operating Instructions	23
2D Project	23
3D Grid Project	26
ObjectMapper Projects	32
Positioning Menu	38
File Manager	38
MALÅ GeoDrone 80 Project	39
System Menu	41
GPS options and settings	44
Wi-Fi option and settings	46
Troubleshooting	51

Preface

About this Manual

This manual is written for the end user of the product and explains how to set up and configure the product, as well as providing detailed instruction on its use.

Additional Resources

Training: www.guidelinegeo.com/training-gpr-resistivity-seismics-tem/
Downloads: www.guidelinegeo.com/support-service-advice-training/resource-center/
Applications: www.guidelinegeo.com/application-areas/

Feedback

Feedback regarding the contents of this manual or the product may be sent by using any of the channels found at www.guidelinegeo.com

Get Ready. Set up. Go

This user manual walks through the steps for getting ready, setting up and basic operation of your new MALÅ Ground Explorer (GX) System. In this user manual the GX Controller, the data collecting monitor, is explained.

Information on the MALÅ GX antennas are found in separate user manuals, the *MALÅ GX Antennas User Guide* and the *MALÅ GeoDrone 80 User Guide*.



MALÅ Ground Explorer HDR Features

MALÅ GX (Ground Explorer) is an integrated GPR solution with a wide range of antenna options. Through the unique HDR technology, the MALÅ GX system offers significantly better data quality and faster acquisition rates. The GX series of antennas are fully integrated with the GX Controller or a mobile device with MALÅ Controller App installed as well as MALÅ Vision for viewing and post-processing of data. The MALÅ GX is an easy to use and field proof GPR solution for a wide range of applications.



Advantages compared to conventional GPR technology:

- Real-time sampling technology – HDR enabled
- Significantly faster data acquisition rates
- Greater signal-to-noise ratio
- Increased bandwidth
- Unprecedented dynamic range and resolution
- 32-bit data output
- Greater depth penetration
- Better detection capabilities
- Data collection with dedicated GX Controller or tablet with the MALÅ Controller App

Accessories

MALÅ Controller /PC Holder

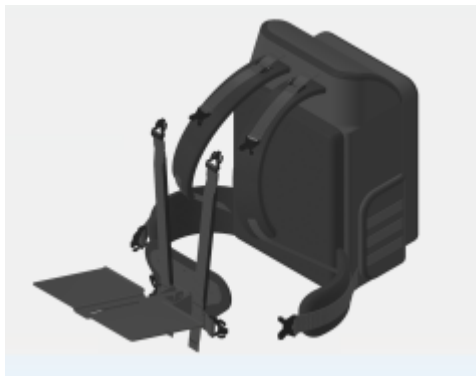

Use a MALÅ Backpack with Monitor/PC holder or a GX Controller shoulder harness.

Shipping Cases



Robust shipping cases for the MALÅ GX Controller and accessories.

Other Accessories

- Battery bag for extra power.
- Encoder wheels
- Pulling kit
- Skid plates

Unpack. Inspect. Register

Great care should be taken when unpacking the equipment. Be sure to verify the contents shown on the packing list and inspect the equipment and accessories for any loose parts or other damage.

Note: The packing list that is included with the shipment should be read carefully and any discrepancy should be reported to our sales department at www.guidelinegeo.com

Note: All packing materials should be kept if any damage occurs during shipping.

File any claim for shipping damages with the carrier immediately after discovery of the damage and before the equipment is put into use. Any claims for missing equipment or parts should be filed with Guideline Geo within fourteen (14) business days from the receipt of the equipment.

Repacking and Shipping

The Guideline Geo packing kit is specially designed for shipping MALÅ GX HDR. The packing kit should be used whenever shipping is necessary. If original packing materials are unavailable, pack the instrument in a box that is large enough to allow at least 80mm of shock absorbing material to be placed all around the instrument. This includes top, bottom, and all sides.

Warning: Never use shredded fibers, paper, or wood wool, as these materials tend to pack down and permit the instrument to move inside its packing box.

Please read our shipping instructions before returning instruments to Guideline Geo. These instructions can be found on our website at www.guidelinegeo.com.

Registering MALÅ GX HDR

By registering your equipment, you ensure that you receive up-to-date documentation, software upgrades and product information, which all helps to optimize the utilization of the equipment and realize the maximum return on your investment.

To register your equipment, simply visit – www.guidelinegeo.com/

Note: The serial number is found on the underside of the GX Controller and on top of the antenna.

System set up

MALÅ GX is an integrated system, consisting of a GX Antenna and a GX controller, linked through Wi-Fi communication or a single data/power cable.

Note: Instead of the GX Controller the MALÅ GX system (if Wi-Fi enabled) can also be operated with a mobile device and the MALÅ Controller App. For more information see *MALÅ Controller App User Guide*.



The MALÅ GX GPR system can either be pulled, with a rough terrain skid plate or pushed in a MALÅ Rough Terrain Cart (RTC or RTC Mini).

When using a cart, the MALÅ GX Controller is mounted on the handle of the MALÅ RTC or RTC Mini with a monitor holder.

When using a skid plate, the MALÅ GX Controller is mounted on a backpack or shoulder harness.

Use the two supplied knobs or Velcro to mount the controller on the RTC holder, backpack or shoulder harness.



Connecting it all up

Connect the data/power cable between the GX Controller and the GX antenna.

If using Wi-Fi, see the settings in section *Wi-Fi option and setting*.



Note: Look for the countersink in the power cable and place it towards the mark on the connection. Push lightly. If you have it in the correct orientation it will go into its position smoothly. To disconnect, pull out holding the metal part of the connector.

Instructions on other GX antenna connections, as wheels is explained in the *MALÅ GX Antenna User guide* and *MALÅ GeoDrone 80 User Guide*.

Power up

Start the MALÅ GX system by pressing the power button on both the GX antenna and the GX Controller.

Note: The GX Controller start menu appears about 20 seconds after turning on the monitor and GX antenna.

Power down

To turn the antenna and monitor off, first select Shut down from the Start Menu, confirm the action by selecting YES. When the monitor screen is black, push the power button on the monitor and release quickly.

Note: The antenna will automatically turn off when the monitor is powered down.

Note: If a power cable is accidentally pulled out, the MALÅ GX components will start automatically when reconnected.

Power and Charging

The GX Controller is powered by an internal battery. Connect the supplied power supply/battery charger to the socket on the right-hand side of the GX Controller data/power connectors.



The battery indicator on the GX Controller will show the charging cycle.



The red lightning bolt indicates the GX Controller is charging.

The green lightning bolt indicates the GX Controller is fully charged.



Note: The bar on the top row indicates the battery level in the GX Controller, the bottom row indicates the battery level in the GX antenna battery.

Tip: The GX Controller can be charged without the need for the monitor to be switched on. The charge cycle will take 3 - 4 hours to complete if fully discharged.

The temperature when charging should be within 0 to +45°C / 32 to 110°F. Do not charge the GX Controller in direct sunlight or when surrounding temperature is below freezing point.

You can also power the GX Controller with an optional battery bag. This bag has two outlets, so it can power both the GX Controller and the GX antenna at the same time.



User Interface

The following sections contain a detailed description of the user interface in the GX Controller and give tips and warnings designed to help the user achieve the highest possible level of productivity and safety while operating the MALÅ GX GPR system.

Start Menu

The MALÅ GX Controller uses dedicated software designed specifically for the display and collection of GPR data.

Note: The GX Controller utilizes a sunlight readable LCD display for maximum visibility in daylight.

The Start Menu has the different project options, the Positioning information, File manager and the System Menu button 

The  icon indicates the connection status to the antenna.

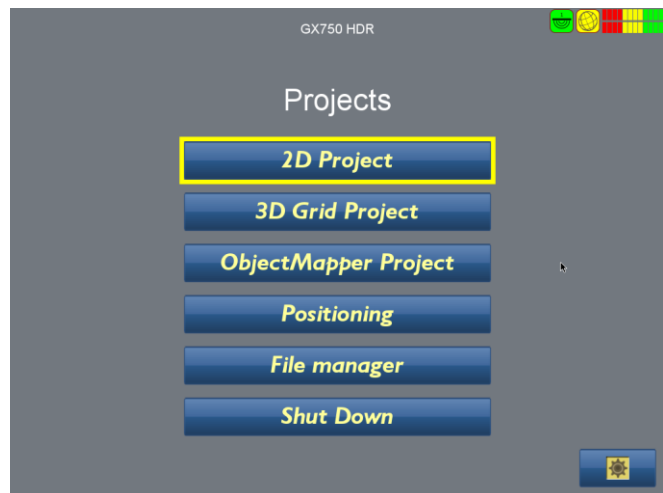

If Wi-Fi is activated a list of connected antennas are also displayed in the Start Menu.

More antennas can be added, see section *Wi-Fi Option and Settings*.

Navigating the Menus and Options



The GX Controller operates with a dual function Navigator button for selecting options and functions. Menu items are selected by rotating the Navigator clockwise or anti-clockwise. The selected item is then executed by pushing the button.

The Navigator works in a similar way to a computer mouse allowing the user to navigate menus and update data. Rotating the knob either allows sequential scrolling through menu options, to make a menu selection, or changes selected parameter values. Pressing the knob either executes the currently selected menu option or sets the value of the selected parameter.

Note: By pressing down, hold and rotate the knob you can fast scroll.

Main 2D Project Menu

As 2D projects are the most common ones, the different main user interfaces are explained with this project type.

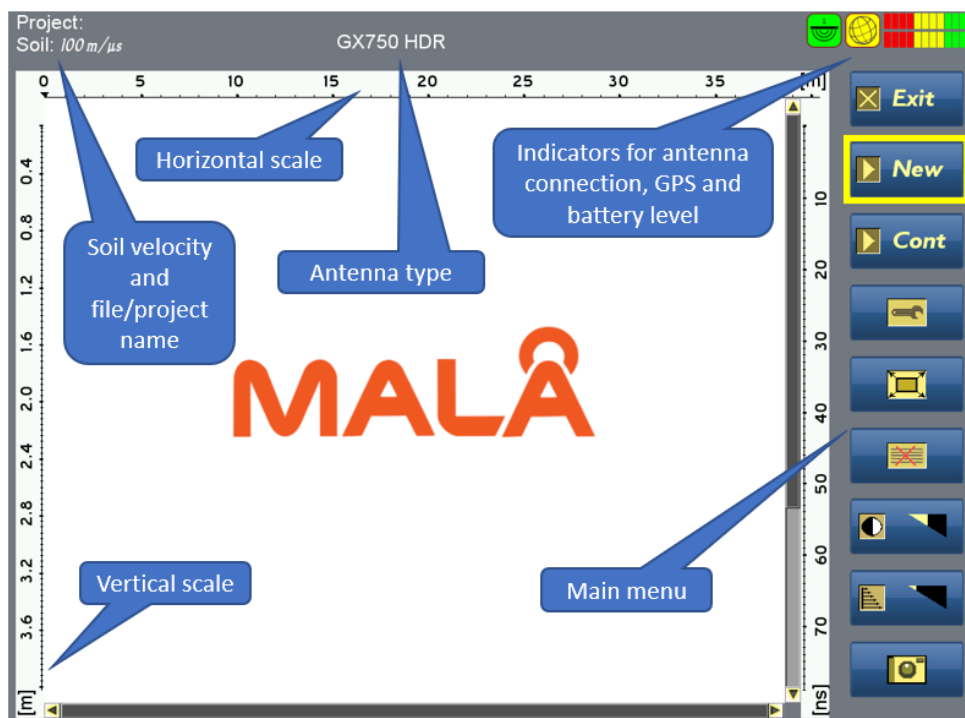

The items available under the Main Menu vary depending on whether the system is in Stopped mode or Started mode.

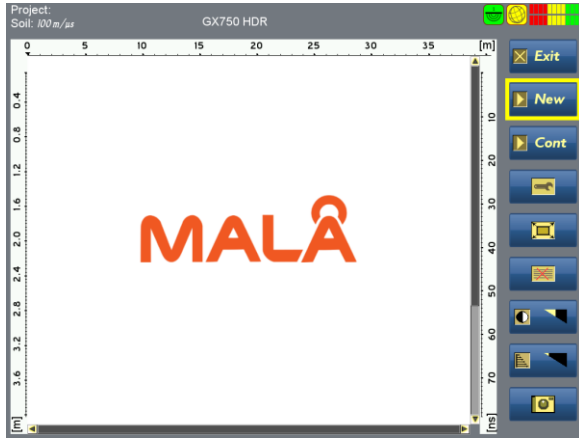

Stopped mode

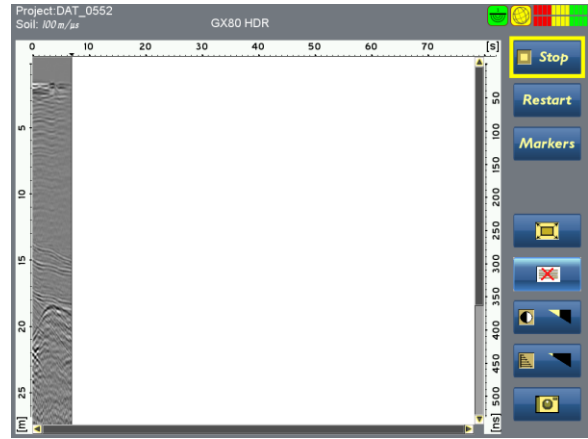

Started mode

Zoom Function

Use the Navigator to select the vertical scrollbar. The vertical scrollbar turns yellow when selected. Push the Navigator once to activate scrolling. The vertical scrollbar will turn blue indicating that it has been activated. Push, hold and turn the Navigator to zoom in and out. This is indicated with a blue vertical scrollbar with arrows.



Main Menu Icons



Exit is used to return to the main menu.

Note: If the *QUIT* option is executed but the GX Controller is not turned off immediately, the unit must be put through a power cycling sequence before it can be restarted. This is achieved by pressing the power switch on the GX Controller and then waiting for 5-10 seconds before pressing the power switch again. If this procedure is not followed, the unit will fail to turn on.



Select the *New* button to start scanning. The GPR data will begin to appear on the black screen as the unit is moved forward.



Select the *Continue* button to resume the last stopped measurement.



Press the *Measurement Parameters* button to access the measurement parameters menu. See the *Measurement Parameters* section for more information on the use of this option.



The *Full screen* button toggles the display to full-screen mode where the menu and status information are hidden, and the entire display is used to display the GPR profile.

Note: Pressing the Navigator again returns the display to the default with the menu included.



The *Background removal filter* button is used to remove horizontal lines/reflections caused by noise from the GPR profile. By rotating the Navigator, various levels of background removal can be applied. The effect of the filtering can be seen when the button is deactivated, the level can be gradually adjusted to create the clearest and most interpretable image possible.



The *Contrast* button is used to set the contrast of the GPR profile. Rotating the Navigator increases and decreases the contrast level.



The *Time gain* button is used to adjust the time gain for the GPR profile. The Navigator is rotated to increase or decrease the applied time gain.



The *Screenshot* button makes a jpg image of the current radargram and can be downloaded from the File Manager.

Note: When the Auto Gain option in the System Menu is selected, the manual time gain is deactivated and removed from the main screen.

Tip: Gain is very useful for making targets appear brighter in the GPR profile, this is especially important when searching for deeper targets.

Measurement Parameters Menu

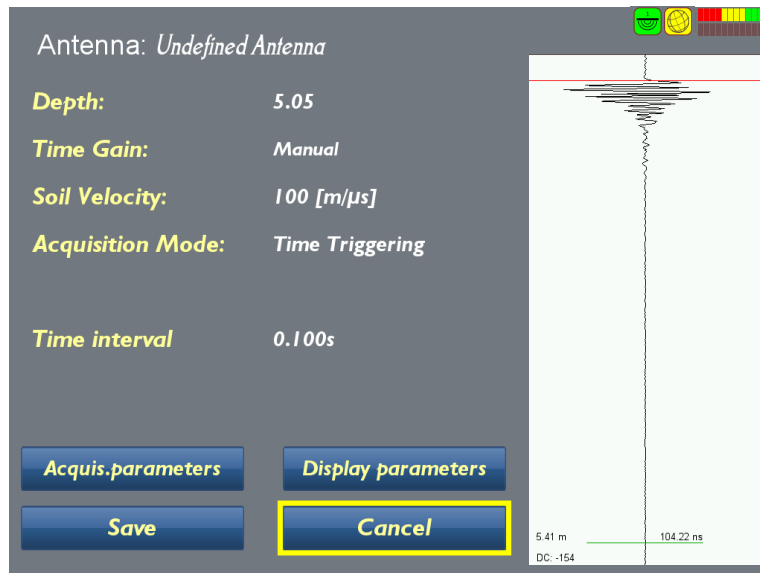

Depth:

Depth defines the length of the radargram vertical scale. This is sometimes referred to as the time window length. In this case, the the set velocity is used to calculate the depth window.

Note: This value will vary if the soil velocity is changed.

Time Gain:

Set to manual or auto (Automatic Gain Control).

Note: Manual gain activates the Time Gain button on the main screen and allows the user to manually adjust the gain. Selecting Auto deactivates the Time Gain button on the main screen and the GX Controller will apply the highest gain level for the signal to noise ratio.

Soil Velocity:

Set the velocity based on soil type. Setting the velocity allows the adjustment of the depth scale for differing soil conditions.

Warning: This is a critical setting if accurate depth information is required. Soil conditions can vary rapidly with location and all depth information must be used with caution.

Tip: The velocity can be set during the post-processing stage; it is not critical that this measurement is established during the data collection stages, unless marking the depth on site.

Acquisition Mode:

Set the type of trigger to be used for initiating a measurement. Three triggering options are available: Wheel, Time, or Keyboard Trig.

Note: Changing the three different trigger options will change the options listed below the Acquisition Mode.

Note: When measuring by time, make sure that the time interval is appropriate and suitable for your measurement pace.

Wheel type:

Select between predefined measurement wheels and encoders from a drop-down list:

Trigger List
Wheel (17cm)
Wheel (30cm)
Rough Terrain Cart
Hip chain

Tip: Additional wheels and individual calibration can be added to the list by accessing the *Acquisition Parameters* menu.

Note: The accuracy of the encoder wheel is not infinite and depends on several factors, such as the measurement surface, the pressure applied on the wheel and possible wear. If you are unsure of the encoder wheel accuracy, a re-calibration should be made.

Point interval:

Point interval sets the distance between the measured points/traces in the radargram.

Acquisition Parameters Menu

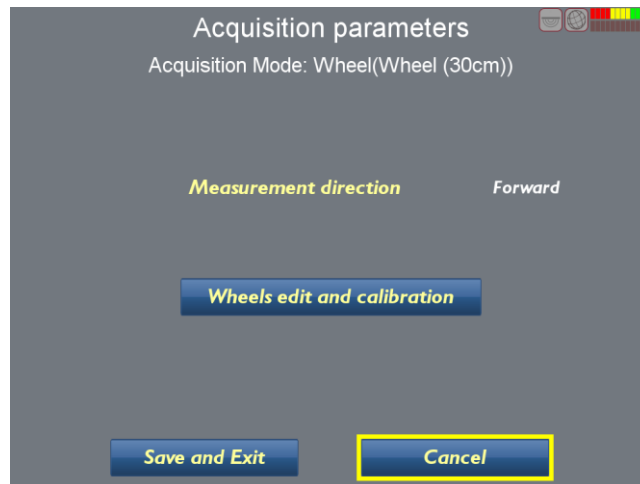

Measurement direction

Choose Forward or Backward depending on the direction of the scan whilst utilizing the Measuring Wheel or Cart.

Note: This option will not be available when Time or Keyboard Triggering is selected on the *Measurement Parameters* menu.

Wheels edit and calibration

Select the *Wheels Edit and Calibration* to enter the Wheels menu. See below.

Wheels Edit and Calibration Menu

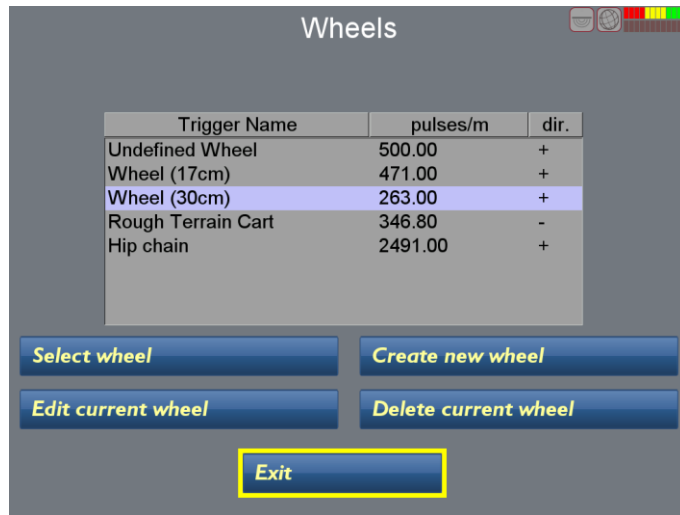

Select wheel

Choose the *Select wheel* to highlight the wheel to be edited or deleted from the list.

Create new wheel

Or choose the *Create new wheel* option which allows the user to select a new type of wheel in addition to the standard list.

This may be useful if the encoder is attached to a non-standard wheel.

Edit current wheel

Then select *Edit current wheel* calibrate the wheel, see *Wheel Edit Options* section below for further details.

Note: First use the *Select wheel* option to highlight the wheel to be edited.

Delete current wheel

Choose the *Delete current wheel* option to remove a selected wheel from the list.

Note: First use the *Select wheel* option to highlight the wheel to be deleted.

Wheels Edit Options



Wheel name

Select *Wheel Name* to create a name for the new wheel.

Direction of calibration

Select Forward or Reverse depending on the direction of the wheel during the calibration process.

Distance for calibration

Measure a distance on the ground using a measuring wheel or tape. Enter this distance after selecting *Distance for Calibration*.

Tip: For a higher level of accuracy, measure a length over the surface where the GPR is being used. A longer distance will average out any surface variations.

Start calibration

Select *Start calibration* once the correct details are entered into the above options and when the GPR is positioned over the beginning of the measured length.

Move the GPR towards the end of the measured length, when this process is complete, select *Stop calibration*.

Display Parameters Menu



Palette

The palette refers to the display of the radargram, there are three options: one grey scale and two different color options.

Trace View

If trace view is ON, a small window will appear on the right-hand side of the radargram during measurements, showing the actual measured trace.

Backlighter(%):

The intensity of the screen light can be changed with the backlighter option.

Tip: Reducing the backlight will extend the battery life between charges.

Save and Exit

Saves changes and exits to previous screen

Cancel

Closes the Menu without applying changes.

Operating Instructions

The following sections walk you through more advanced modes of operation of the equipment, the 2D Project, 3D Grid project, Object Mapper project and the use of GeoDrone 80. Further on, the System settings are described, with e.g., GNSS and Wi-Fi settings.

2D Project

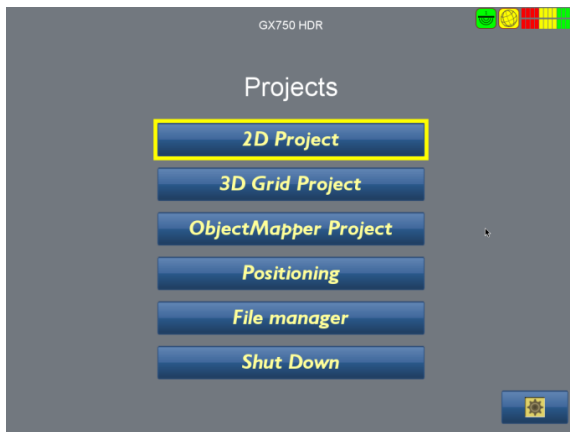

Select *2D Project* from the main screen options to conduct a simple 2D profile.



Select *New* to begin the measurement.

See *Main 2D Project Menu* section for a full description of the different menus.

Note: Check Settings before commencing a measurement. See section *Measurement Parameters Menu* above.

Markers

Various markers can be inserted into the radargram by selecting the *Markers*.

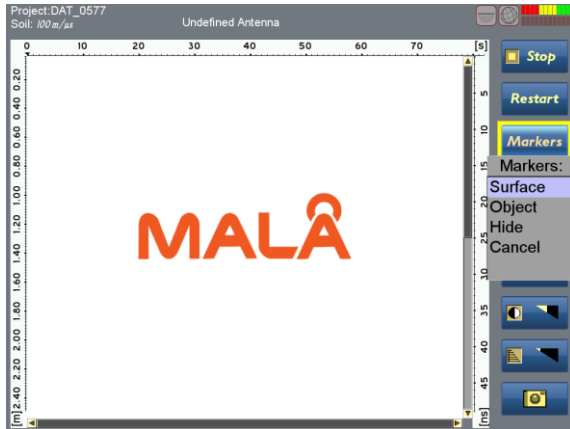

A dropdown box containing the marker options will appear when the Markers is selected:

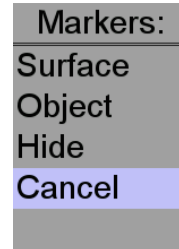

- *Surface* marker allows a marker to be placed at zero depth level on the radargram. This is useful for marking a feature that is visible on the surface. It can be marked as you pass the feature or simply reverse the GX HDR antenna over the feature and then select *Surface*.
- *Object* marker allows a similar marker to the surface marker to be placed at a selected depth within the radargram. Reverse the GX antenna over the feature and select *Object*, a crosshair will appear on the vertical cursor which can be positioned at the correct depth by using the Navigator control.
- *Hide* removes the markers from the display. This is not permanent; the markers can be made visible again by selecting *Show*, which is indicated after *Hide* is selected.
- Select *Cancel* to exit the Marker Menu.

Note: Markers are saved in a text file with the extension *.mrk. This file gets the same name as the data file.

Tools

Select *Tools* to enter the Tools Menu.

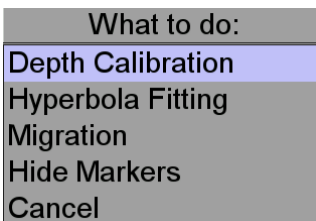

A dropdown menu appears when the Tools menu is selected.

- *Set Soil velocity.* If the soil velocity has been determined, enter the value by selecting *Set Soil Velocity* icon and then use the Navigator to set the correct figure.

- *Depth Calibration.* If the true depth of an item is known, place the antenna so the vertical cursor is positioned over the feature in the radargram, select Depth Calibration to activate the cross-hair and use the Navigator to position the horizontal cursor at the top of the reflector with known depth. Press the Navigator and enter the value for the true depth. Finally, press the Navigator again to accept the value and the GX Controller will automatically calculate the velocity based on the entered value.
- *Hyperbola fitting.* If there is a clear hyperbolic response in the radargram, utilise the Hyperbola fitting feature to calculate the velocity of the soil. Position the antenna so the vertical cursor is over the hyperbola, press the Navigator to activate the horizontal crosshair and rotate the Navigator to place the crosshair on the top of the hyperbola. Press the Navigator to reveal the simulated hyperbola, now rotate the Navigator to increase or decrease the simulated hyperbola so it “fits” the true hyperbola in the radargram. Press the Navigator to complete the process; the calculated velocity will be saved.

Tip: To move the crosshair up and down faster, press down the Navigator and rotate at the same time.

- *Migration.* This option applies migration to the dataset, which will have the effect of removing the hyperbola to leave a point in the radargram. First, complete any of the above velocity calculations to determine the soil velocity and then select Migration to apply the process to the radargram.

Tip: Accurate calculation of the soil velocity is required for the migration to work effectively. Depth Calibration is often the most accurate and this should be the first option if available.

3D Grid Project

3D Grid Project is a tool that makes the gathering and visualization of radar data measured in two perpendicular directions easier.

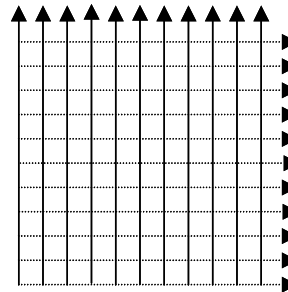

A typical Grid Project can be used to map a larger area where the direction and location of utilities for instance is unknown. It enables the use of a plan view of reflections to visualise the utilities. The Grid Project option in the GX Controller will guide you through all steps involved in the data collection to the final processed 3D view of the area investigated.

Tip: Use Guideline Geo's *MALÅ Vision* software for easy visualization of 3D Grid Projects.

Creating a 3D Project

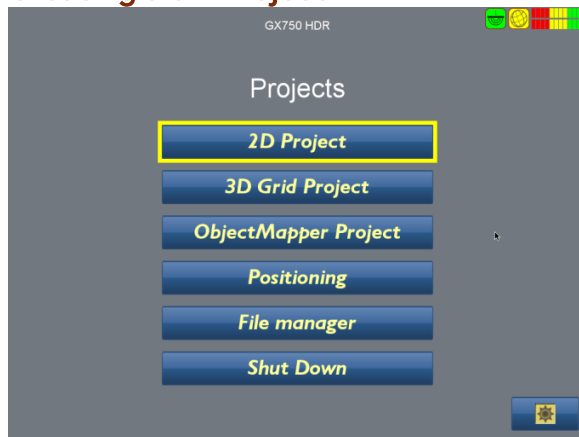

Select *3D Grid Project* from the Start Menu.

The New Grid Project screen appears, the user has the opportunity to select the relevant parameters before data collection begins. The parameters are size of the grid, spacing between lines (profiles) and point interval (trace interval). These parameters are not changeable once the project has been created.

Tip: The text fields with information on site, customer, name etc. can be changed afterwards.



First enter the size of your grid.

Using the Navigator, select and edit the X-size and Y-size.

Then select and enter the *Point interval* for the measurement between the traces.

Next select and enter the *Line spacing* for the measurement between each profile.

Customer, Operator and *Site* details can be entered along with any additional *Comments*.

Finally, select *Start the Project*.

Note: The maximum size of grid will be determined by line spacing, point interval and time window values.

Note: Line spacing must be evenly dividable by Point interval.

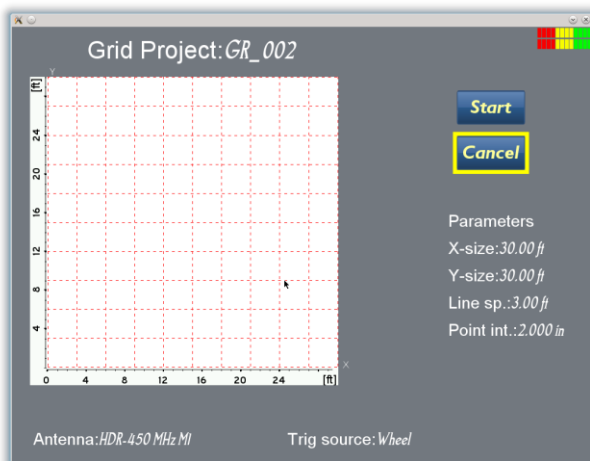

Before the project commences, a summary screen indicating the chosen settings can be reviewed.

A plan view of the grid and its size is also shown.

Select *Start* to move onto the next screen or *Cancel* to move to the previous screen.

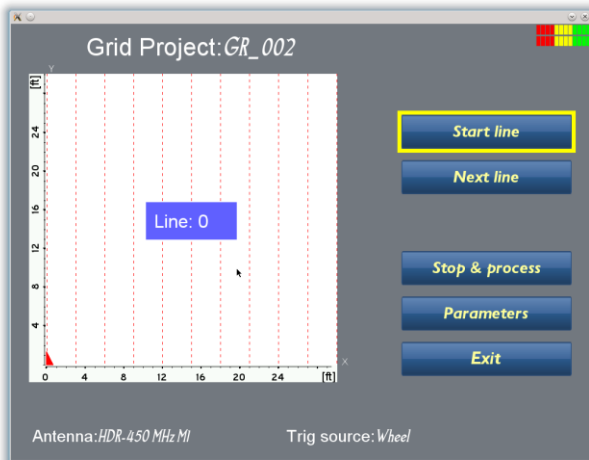

Position the GX antenna in the X=0 and Y=0 position, pointing the antenna in the direction of the Y axis, as indicated by the small red triangle, and dashed red line.

Select Start Line.

Move the antenna to the end of the line.

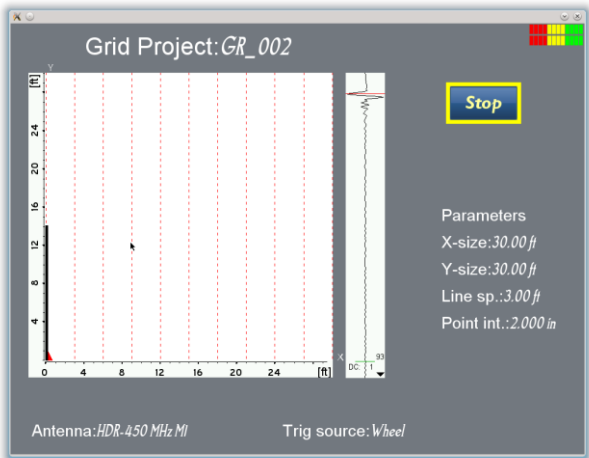

As the antenna is moved forward, a black line indicates the progression along the grid line.

If a mistake is made during the measurement, or the line is not completed, select *Stop* and then *Start Line* again to redo that line.

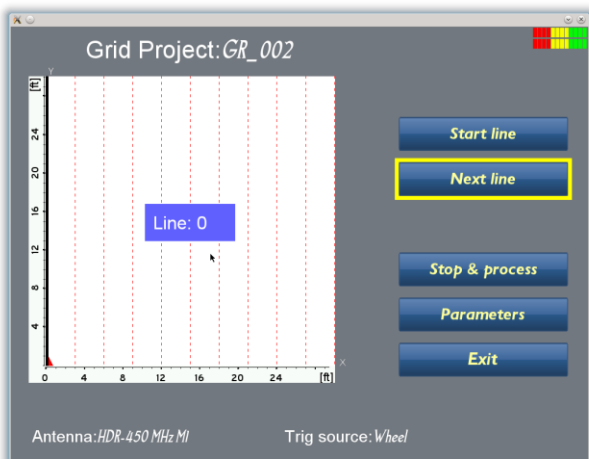

When the line is completed, the GX Controller will indicate the completed line by changing the screen ready for the next line.

Move the antenna over to the next grid line and select *Next line*. Repeat these steps until the X-axis is completed.

Move the antenna to the start of the Y-axis and continue the measurements along the Y-axis until the grid is completed. Next, select *Stop & Process* to complete the initial processing stage.

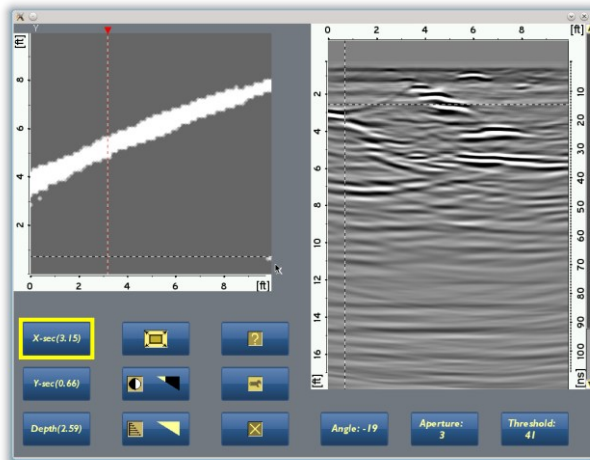

Once the processing is complete, the Grid Project screen shows the plan view and one cross sectional (side) view in the X or Y-axis.

Select **Settings**  to proceed to the next step.



BKGR removal:

Set *BKGR removal* (Background removal) option to ON if removal of horizontal lines in the dataset is required.

Migration Wizard

Next, select *Migration Wizard*, this enables the correct velocity setting to obtain the best possible top view.

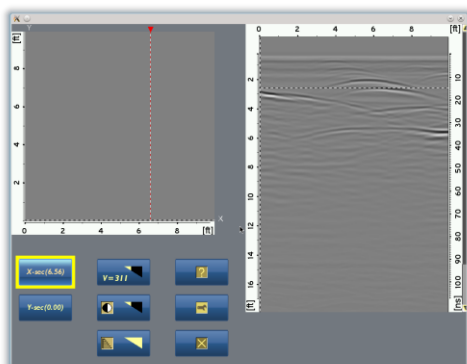

Choose an X or Y cross-section with a well-defined hyperbola.



Select the *Velocity* button and increase or decrease the velocity value until the hyperbola becomes a point.

Tip: Too high a velocity value will cause the hyperbola to invert, reduce the value until the desired response/reflector is achieved. The reflector should be in-between the inverted hyperbola and the standard hyperbola.



Finally, select the *Quit* button to exit and apply the migration to the entire data set.

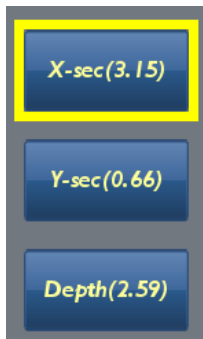

Select the *X-Section* button to view the X-axis data in the side view. When activated, use the Navigator to scroll across the data set.

Select the *Y-Section* button to view the Y axis data in the side view

Select the *Depth* button and use the Navigator to scroll through the time slices in the top view window. Press, hold and rotate for fast scroll.



Select the *Full screen* option. This enables access to the screen capture options.

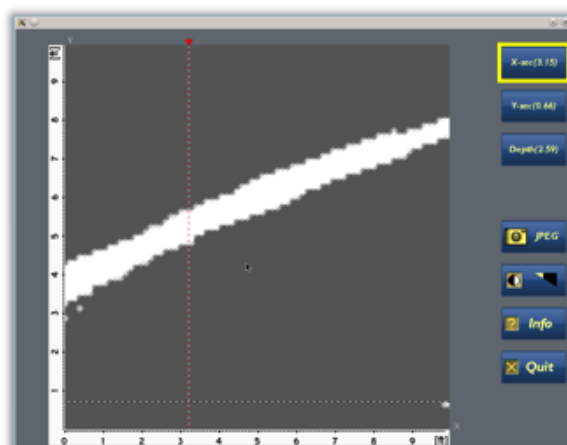



Select the *JPEG* button to access the screen capture options

In the 3D Grid Settings menu the following options are available as well:

Color

Change the color scheme for the GPR profiles. Three options are available, a grey scale and two different color schemes.

Soil Velocity:

Set the velocity based on field tests or soil type. Setting the velocity allows adjustment of the depth scale for differing soil conditions.

Note: This is a critical setting if accurate depth information is required. Soil conditions can vary rapidly with location and all depth information must be used with caution.

Time Gain:

Set to Manual or Automatic gain control.

Note: Manual gain activates the Time Gain button on the main screen and allows the user to manually adjust the gain. Selecting Auto deactivates the Time Gain button on the main screen and the GX Controller will apply the highest gain level for the conditions.

Migration

Select migration to ON, this applies migration to the 3D Project.

Backlighter(%):

Select the correct level of backlight for the ambient light levels. This setting can be adjusted within the range of 0–100%.

Tip: Reducing the backlight will extend the battery life between charges.

ObjectMapper Projects

An ObjectMapper Project is a tool to easily handle and interpret radar profiles acquired with the GX Controller, where a number of radar profiles are linked to a common baseline or positioned with GPS. See the examples below.

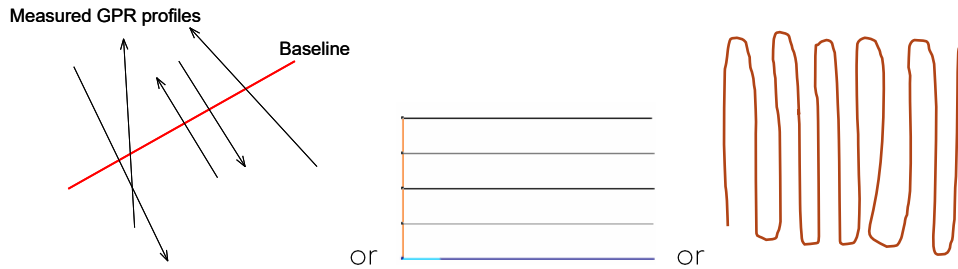

Tip: Use Guideline Geo's MALÅ Vision software for easy visualization of Object Mapper Projects.

Creating an ObjectMapper Project

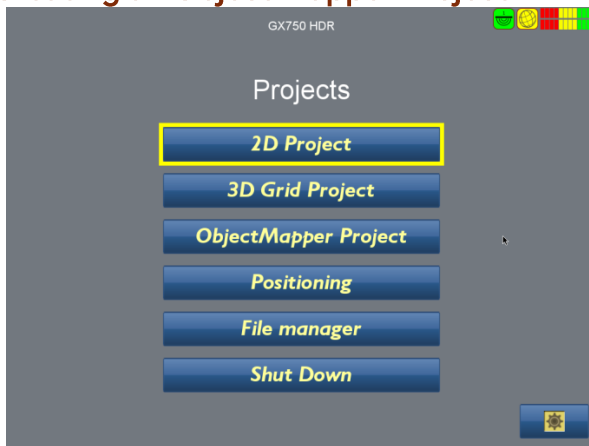

Start working with Object Mapper Projects by selecting *ObjectMapper Project* on the Start Screen.

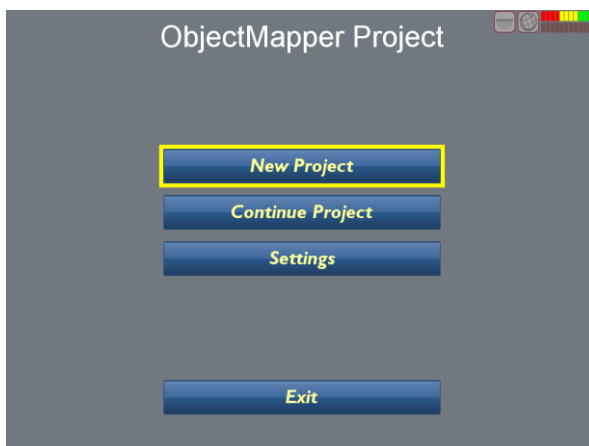

ObjectMapper Project start screen.

Settings

Select *Settings* to apply correct measurement values. See section *Measurement Parameters Menu* for full details.

New Project

Select *New Project* to start the project and move onto the following screen:

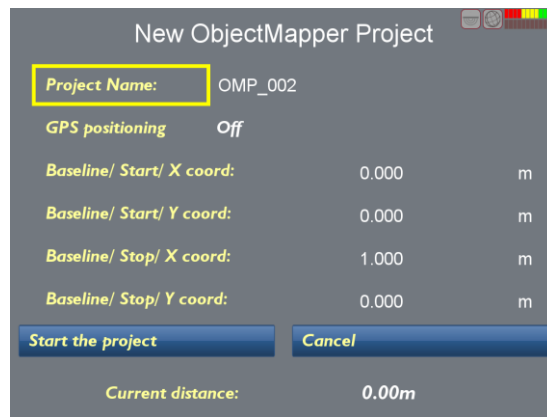

Project Name:

Select *Project Name* to tag a name to the project. Use the Navigator to enter the name, one character at a time.

GPS positioning

To activate the GNSS positioning, set the *GPS positioning* to ON.

Note: If the GNSS option is ON, no baseline is needed, and the X-Y coordinate options are deactivated.

- Baseline/ Start/ X coord:
- Baseline/ Start/ Y coord:
- Baseline/ Stop/ X coord:
- Baseline/ Stop/ Y coord:

The location of the baseline is given by setting the X and Y-coordinates of the start and stop positions of the line. If no coordinates are available, the baseline is defined as 0 m for X and Y start position and then the length of the line for X or Y stop position.

Tip: The coordinates for the baseline can be edited later in MALÅ Vision.

Start the project

When the baseline is defined or GNSS positioning is ON, press *Start the project* to collect the ObjectMapper files.

Tip: In this screen, before pressing Start the project, the GX System measuring wheel can also be used as a measuring tape, showing the travelled distance at the bottom of the screen. To set the measuring tape function to zero, select the *Current Distance* option and press the Navigator once.

Object Mapper Measurements with Baseline

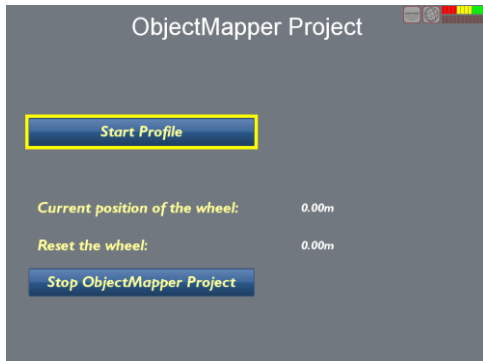

When the Start the project button is pressed, the Start Profile screen appears.



Once *Start Profile* is pressed, the user returns to the ordinary measurement screen. The additional Baseline Crossing icon will be active on this screen.



When passing the baseline, select the menu option *BL Crossing* (bottom button) to place a marker on the GPR profile. This marker will be used to connect the current profile to the defined baseline.

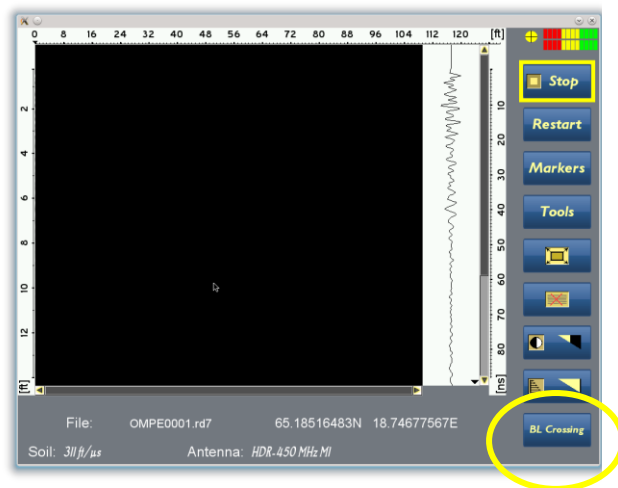

Note: The baseline crossing marker can be created anywhere along the GPR profiles e.g., at the beginning, middle or end but the baseline must cross through all the profiles. If starting the profile directly on the baseline, press *BL Crossing* immediately after pressing *Start*, in other words, before moving the antenna.

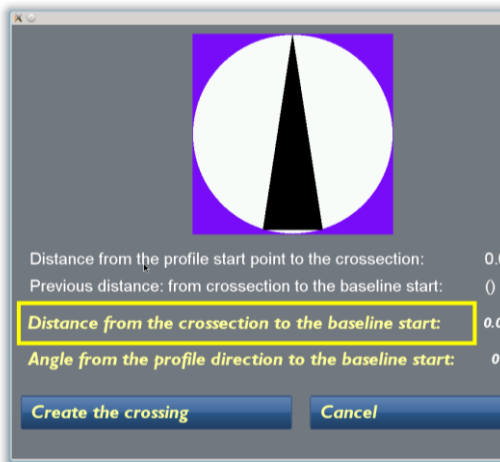

After pressing BL Crossing the screen to the left is seen.

Here the current profile's positioning is defined, in terms of distance from the baseline start point and the direction of the profile in relation to the baseline. See the picture illustration below.

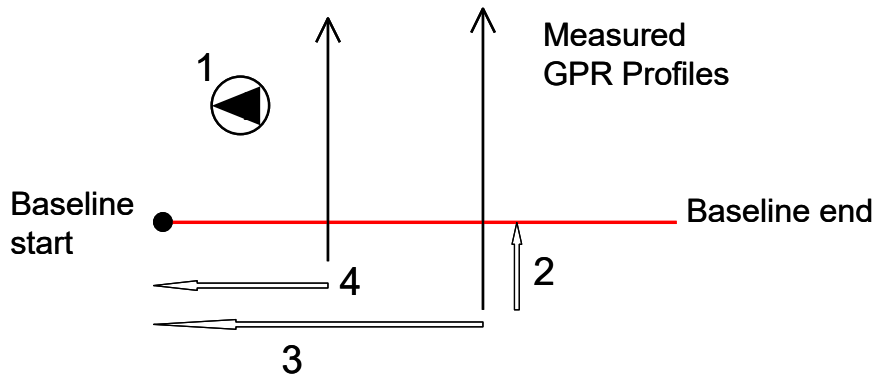

Key:

- 1: Orientation to baseline start point. In this case it is 270 degrees.
- 2: Distance from the start of the current profile to the baseline
- 3: Distance from baseline start to the current profile
- 4: Previous distance

First set the distance from the baseline start point to the current profile. Then select the angle of the profile to the baseline start point. Finally, select *Create the crossing*, the screen reverts to the measurement screen and a blue marker dot is seen on the GPR profile. Continue the measurement along the current profile.

Once a profile is completed, select  and the Start Profile screen will be seen again and a new profile can be started as usual, again applying the BL Crossing option when passing the baseline.

Note: The GX Controller and the ObjectMapper project will automatically suggest the distance and the angle to the baseline start after 3 passes of the baseline.

Tip: Moving in the opposite direction after each profile is finished (i.e. "zig-zag") can optimize data collection. If measuring every second profile in the opposite direction and at a right angle to the baseline the angle from the profile direction to the baseline start will be 270, 90, 270, 90 and so on.

When all the ObjectMapper profiles are measured, select **Stop ObjectMapper Project** on the Start Profile screen to close and save the ObjectMapper Project.

This project is easily uploaded to a computer (see the *Transferring Data* section) where it can be opened in the MALÅ Vision software for simple interpretation of underground features. For further information, see the *MALÅ Vision User Guide*.

Tip: Separate files can be opened or uploaded from the project, enabling the user to view individual profiles if required.

Object Mapper measurements with GNSS

To create a project with GNSS positioning, start a new project and set the *GPS positioning* to *On* and select *Start the Project*.

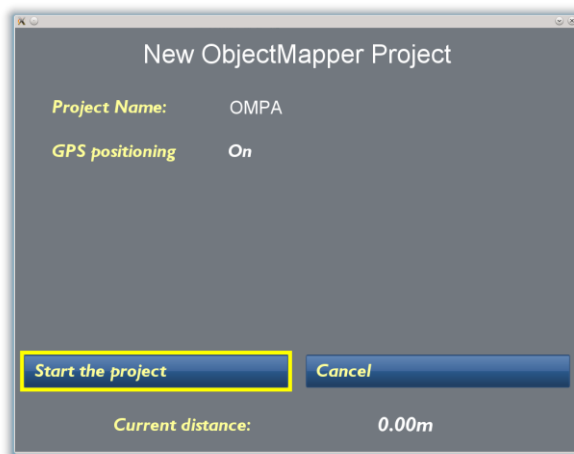

Next, select *Start Profile* and the screen will return to the main measurement screen.

Tip: With GNSS positioning activated, the user can complete one long profile in a zig-zag formation around the area to be surveyed or stop and start profiles to create several parallel profiles.

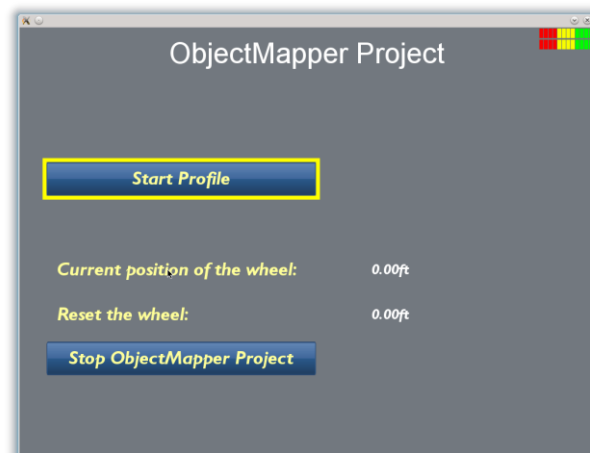

When the project is complete, select **Stop ObjectMapper Project**.

Note: When using the GNSS option for ObjectMapper projects, make sure the GNSS has high precision positioning, as RTK correction.

Continuing an Object Mapper measurements Project

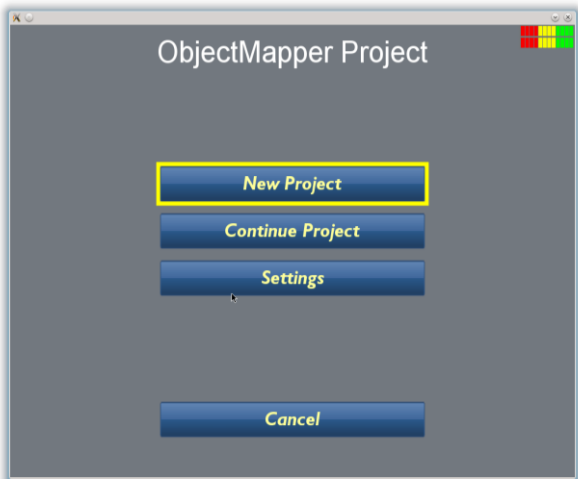

To continue a previously started ObjectMapper Project select *Continue Project* in the Project Main screen.

Use the Navigator to choose between the different Object Mapper Projects in the drop-down menu and press the button to continue the selected project.

Positioning Menu



In the Positioning Menu, the incoming GNSS coordinates are viewed.

Here you also have the possibility to use the connected measurement wheel as a measuring tape.

File Manager

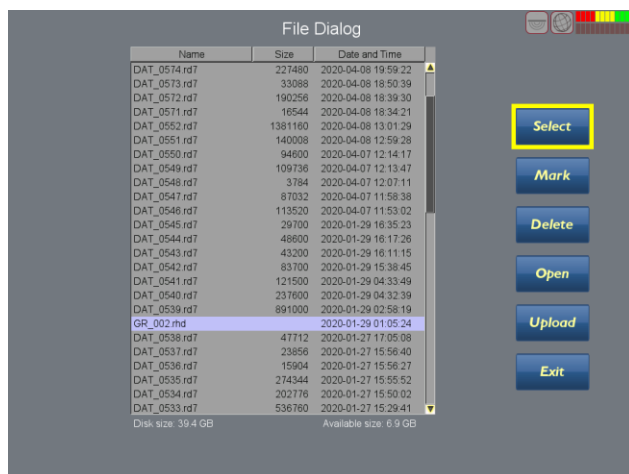

In the File Manager menu all measured files and projects are found. Here you can select, mark several files and delete or upload the same.

2D files has the file extension *.rd7, ObjectMapper projects *.obm and 3D Grid Projects *.rhd.

Note: For the ObjectMapper and 3D Grid Projects all made files in one project are uploaded at the same time.

GeoDrone Project

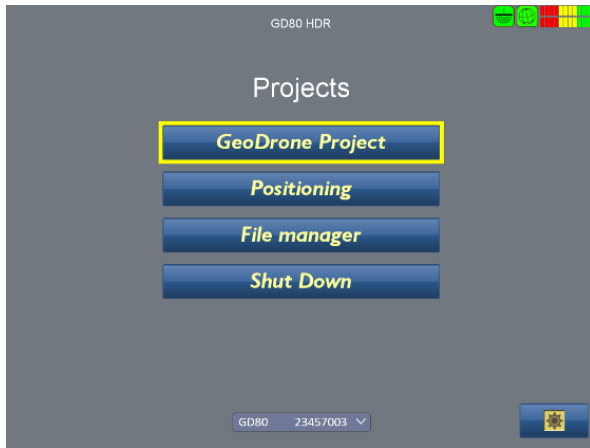

If the GX Controller is connected to the MALÅ GeoDrone 80 antenna, the GX Controller will automatically show the GeoDrone Start Menu options at start.

Press  to start a GeoDrone Project.

The GeoDrone 80 communicates with the GX Controller by Wi-Fi.

The GeoDrone 80 main unit is paired with the GX Controller at purchase. If the GX Controller is used with another GX antenna, choose the GeoDrone 80 antenna in the drop-down list in the main menu. The status of the pairing is indicated in the upper right corner of the Controller.



Wi-Fi switched on and communication established.



Wi-Fi switched on but no communication established. Pairing is needed.

If you need to pair the GeoDrone 80 antenna again, go to *System- and Wi-Fi settings*  and use *Wi-Fi Initiation via Wire*. For more information see section *Wi-Fi Settings* and *Wi-Fi initialization via wire*.

The main screen for GeoDrone 80 measurements have three filters to enhance the radargram during measurement:



Background removal



Contrast



Time gain



The default measurements settings are satisfying for most applications, if necessary, adjust settings in the Settings menu . Also see section *Measurement Settings* below.



Start New Profile and you are ready to go.



Note: The antenna has an in-built data storage module, which enables data to be stored whilst taking measurements. This enables a more secure way of data collection as data transmission can be interrupted when utilizing Wi-Fi. Data is restored to the Controller when Wi-Fi connection is established again or by data-cable. For further instructions see section *Restoring missing traces*.

Measurement Settings

In Measurement settings adjustments for depth, gain type, soil velocity and time interval can be changed.

Note: The MALÅ GeoDrone 80 always acquires data by time triggering.

In *Display parameters* you can change e.g., palette and trace view.

The Palette refers to the display of the radargram, where there are options for presenting data in grayscale or color.

If Trace View is ON, a small window will appear on the right-hand side of the radargram during measurements, showing the actual measured trace.

The intensity of the screen light can be changed with the Backlight option.

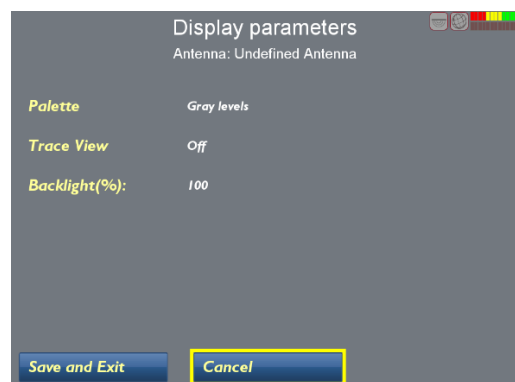
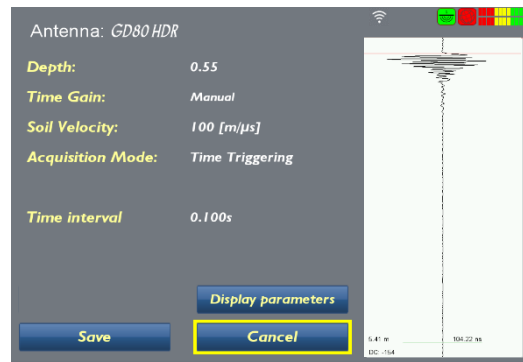

Tip: Reducing the backlight will extend the battery life between charges.

Note: More information on the MALÅ GeoDrone 80 can also be found in the *MALÅ GeoDrone 80 User Guide*.

System Menu

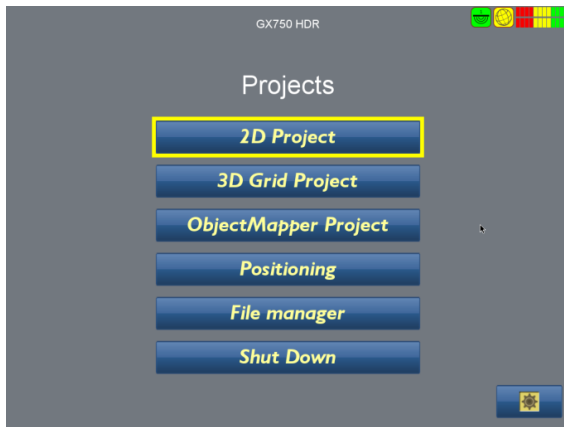

To enter the System Menu, select  on the start screen.

The GX Controller will now enter the System Menu.



Select *Time and date* to modify the internal clock settings.

Select *Battery max level* to set the battery level indicator. Enter 12 (Volts) if a generic external 12 Volt battery is being used; select 11 for the MALÅ battery packs.

PowerSave Mode allows the user to activate or de-activate the backlight dimming option.

Select *Imperial or SI* for the appropriate local requirements.

Hardware Tests

Select the *Hardware Tests* to enter the hardware test screen. Select *Start Test* or *Start Ethernet Test* to start the self-test procedure. Each item of hardware will be tested sequentially with the results of each test displayed on the screen and written to a file. Once the test is completed, select *Upload "test_results.jpeg"* to save the results to USB memory device.

Data Disk Format

Data Disk format is used to reformat the SSD data storage device in the GX Controller.

A confirmation dialog is displayed before commencing this operation.

Tip: It is recommended that reformatting is performed periodically to maintain peak performance for data management.

Note: Reformatting does not affect the operating system or the GX Controller software.

Software Upgrade

The GX Controller software can be upgraded by downloading the latest software from the downloads page of the Guideline Geo website and transferring them onto a USB data storage device.

Copy the file `ram10img.gz` (and parameter files: `eeprom_1`, `eeprom_2` if they exist) to the root of a USB data storage device.

Insert the USB data storage device into the GX Controller USB port and select *Software Upgrade*. If a confirmation request is displayed, accept the request by selecting *YES*.

The upgrade can take several minutes to install and the GX Controller will re-boot after installation.

Warning: Make sure the batteries are fully charged before starting the software upgrade and DO NOT turn off the GX Controller while the upgrade is in progress.

Restore Predefined Settings

Use *Restore Predefined Settings* option to perform a reset when experiencing problems, or if you would like to reset the settings to a predefined state. A confirmation dialog is displayed before reset operation is performed.

Note: This restore is a low-level reset and should be performed as the first option before executing the Restore Factory Settings option.

Restore Factory Settings

Select the *Restore Factory Settings* option and press to perform a reset when experiencing problems, or if you would like to reset the settings to the default factory settings. A confirmation dialog is displayed before reset operation is performed.

NEXT SCREEN >>

Select *Next Screen* to access additional System Menu options.

Default Start Depth value determines the depth window at start of a scan. The entered value has no effect on the total depth of the time widow.

Select *GPS ON/OFF* to toggle the GNSS function on or off depending on requirements.

Select the rotation direction of the Navigator by toggling Navigator invert rotations False/True.

GPS options and settings

GPS Parameters

Select *GPS Parameters* to enter the settings screen for the different GNSS options.

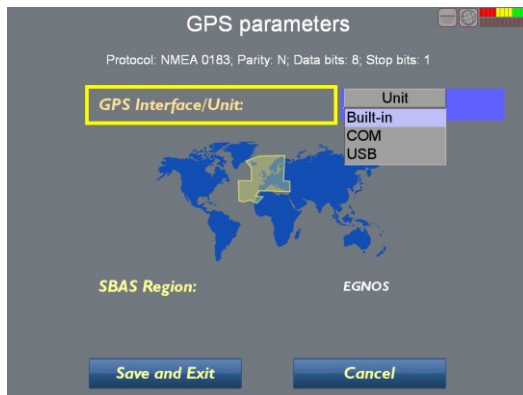

There are 3 options for the GPS Interface/Unit setting.

Built-in, this option selects the built-in DGPS module. Select the correct SBAS Region for your area.

COM, this option is selected for a GNSS (as an RTK GPS) input via the serial COM port. Once this option is activated, various parameters will be activated, see below.

USB, select this option if a simple DGPS antenna is attached to the USB port.



Choose the correct SBAS Region for your measurements. The different regions are displayed on the map as you toggle between them.

Note: The correct GNSS output settings are seen on top of the GPS parameters screen.



When choosing COM port for *GPS Interface/Unit*, settings for accuracy, baud rate and check sum can be made.

The *Select accuracy for green* option allows the user to set the tolerance for the GNSS precision indicator that is displayed at the top right of the monitor's screen while in Started mode.

Use the High setting if utilising an RTK GPS.

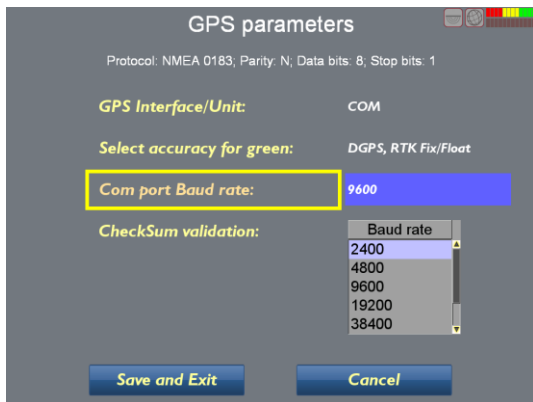

Select the correct values for the *Com Port Baud Rate* and *CheckSum Validation* to match the external GNSS output.



No GPS Low Medium High

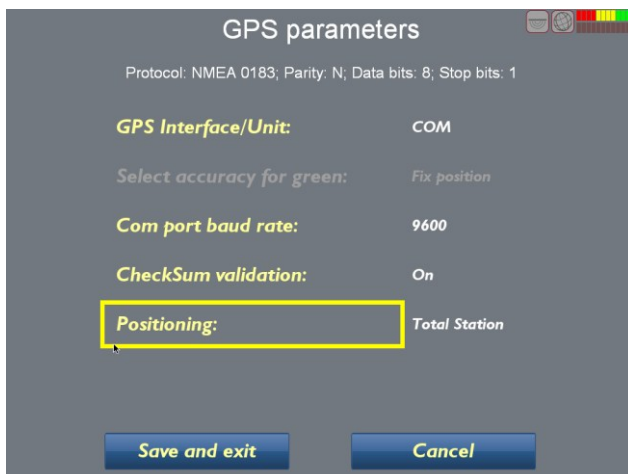

For positioning you can also choose Total Station input. You find this option in the Positioning list.

The option for Total Station positioning is only available by COM port communication.

Wi-Fi Option and Settings

The Wi-Fi option enables the user to connect the antenna to the GX Controller without the use of the data cable i.e., wireless. This may be desirable when the antenna is used remotely from the GX Controller.

If you are using the GX system in one of the cart options (RTC or RTC Mini), we recommend that you use the wired option as this will give a more stable connection between the antenna and the GX Controller and longer battery life.



Antenna with activated Wi-Fi (blue LED)

Note: Using the Wi-Fi option will increase battery consumption and therefore reduce the life of the batteries. In addition, the operational speed of the system will be reduced.

Wi-Fi Connection set up

Remove the data cable between the antenna and GX Controller. Power up the system as normal and check that the Wi-Fi button has the blue LED illuminated. If the blue LED is not lit, press and release the Wi-Fi button. The system will take approximately 60-90 seconds to establish communication between the antenna and the GX Controller. Once communications are established, the Wi-Fi and Communications icons will show next to the battery icon (top right corner of the GX Controller) as follows:



Wi-Fi switched on and communication established.

Wi-Fi switched on but no communication established.

Pairing is needed, see below.

If the Wi-Fi icon is not showing, go to the System Menu, continue to the second system menu screen by choosing *Next Screen* and select *Wi-Fi Settings*.

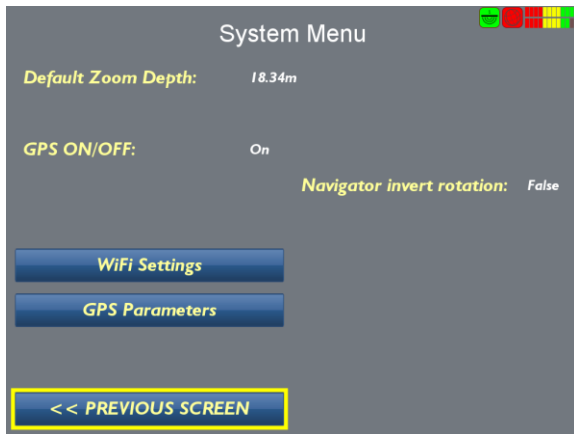

System Menu (screen 2).

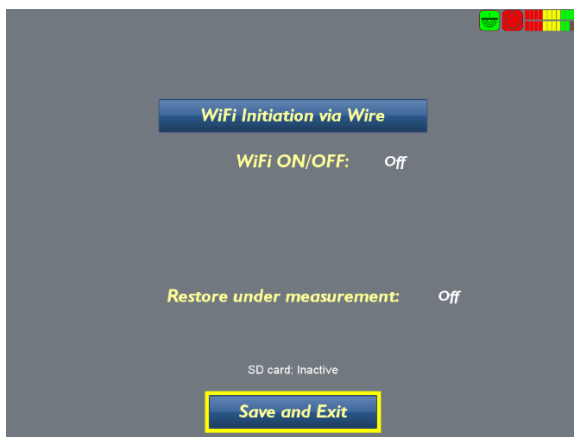

Select the *Wi-Fi ON/OFF* option to activate the Wi-Fi.

When ON or AUTO the Wi-Fi Symbol should be seen in the upper right corner.



If you need to initiate the Wi-Fi (pairing), connect the data cable between the GeoDrone 80 main unit and the GX Controller and choose *Wi-Fi initiation via wire*. See section *Wi-Fi initiation via wire* for more information.

Note: Wi-Fi initialization can take up to 60-90 seconds to complete, please be patient.

Incorporated into the Wi-Fi system is an in-built data storage module in the antenna, this enables data to be stored independently whilst taking measurements to enable a more secure mode of data collection. Data transmission can be interrupted when utilising Wi-Fi and the in-built storage guarantees that data continue to be safely collected during the Wi-Fi drop out. The in-built memory module can also be utilised whilst taking measurements with the data cable connected. This function is automatically activated when the Wi-Fi option is switched on.

Wi-Fi Channel Selection

With this option you can choose an alternative Wi-Fi channel. This may be necessary if the signal is poor during Wi-Fi measurement. The wireless communication may be affected if many devices share the same channel. Choosing the best Wi-Fi channel on your GX Controller helps to reduce interference and improve your Wi-Fi signal.

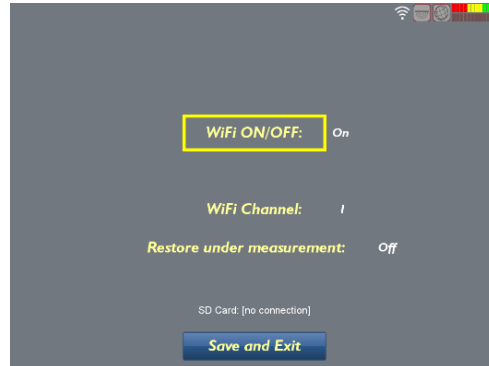

The best option would be to use a Wi-Fi analyser app on your smart phone to ascertain the local Wi-Fi channels that are most congested. Choose and install a free app from the App Store or Google Play and launch it. Use the overview option to see the wireless networks in your area and which channels are the quietest. Some apps will inform you which Wi-Fi channels are better for a good connection.

Once you have chosen the new channel, it will take approximately 1 minute to finish the channel switching.

Restoring Missing Traces

It is possible to move the antenna away from the GX Controller once a measurement has commenced, e.g., during GeoDrone measurements. During this remote operation, or if the Wi-Fi is disrupted when working locally, the in-built memory card in the antenna will store the GPR data thus enabling the measurement to continue. To stop the measurement, the GX antenna must come back into Wi-Fi range of the GX Controller.

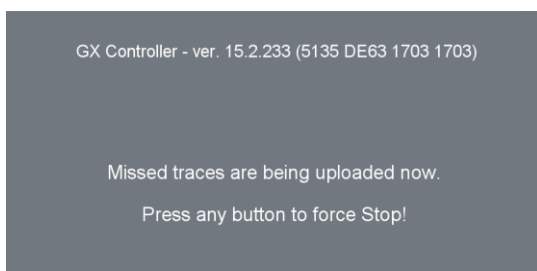

Once the measurement is stopped, and if there are missing traces, the controller will display this message.

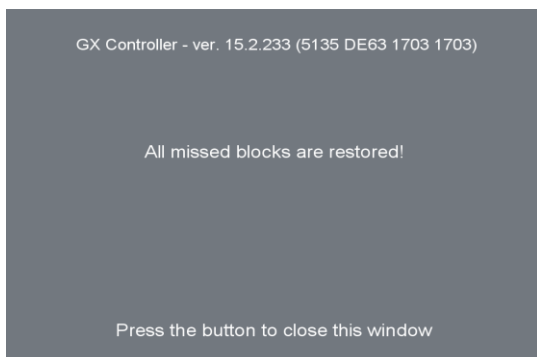

Once the restoration process is successfully carried out, press the Navigator button to close the window.

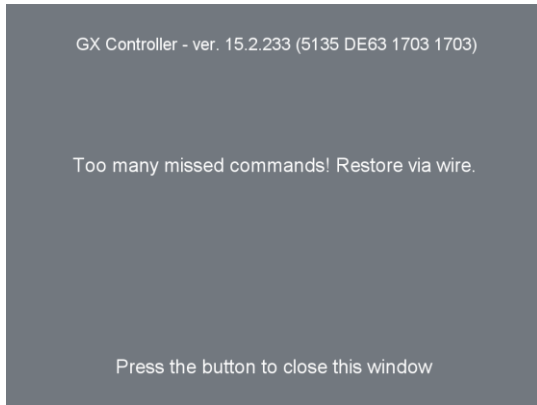

If the Controller experiences difficulties restoring the missing traces, it may be necessary to restore via wired connection.

If this *Restore Via Wire* message is displayed, press the Navigator button to close the window, connect the data cable between the antenna and the Controller. Switch off Wi-Fi on the GX antenna and then proceed to the *Work With Files* option on the Start Screen.

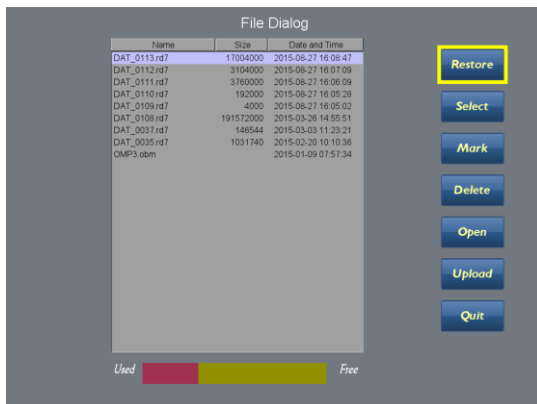

Choose the correct file and then select the *Restore* button.

Note! If the GX Controller or the GX antenna loses power before measurements are properly stopped, data (up to 100 MB) can be recovered (primarily from the last measured profile) with MALÅ Controller App. For further instructions see *MALÅ Controller App User Guide*.

Note! If the Wi-Fi restore is interrupted when using the GX Controller, trace restoration by cable cannot be carried out. Use the data recovery tool in MALÅ Controller App instead. For further instructions see *MALÅ Controller App User Guide*.

Wi-Fi Initiation via Wire

Users may experience occasions when the GX Controller does not automatically connect to the antenna when the Wi-Fi is activated or when the system is switched on.



If this occurs, select the *Wi-Fi Initiation via Wire* in the Wi-Fi settings menu, found in the second screen on the System menus



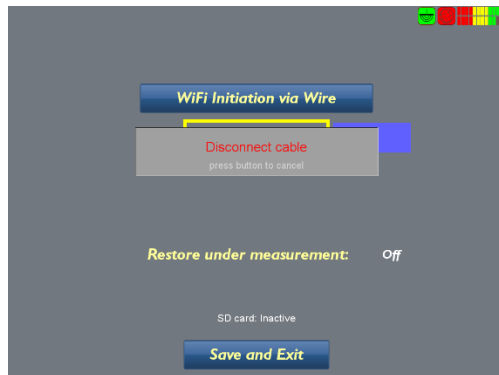

Set Wi-Fi to OFF and connect the data cable between the GeoDrone 80 main unit and the GX Controller.

Press Wi-Fi Initiation via Wire.

Note: Wi-Fi initialization can take up to 90 seconds or more to complete, so please be patient.

Troubleshooting

The MALÅ GX GPR system has been designed to be robust and reliable under adverse conditions. If you encounter a mechanical failure that cannot be fixed on site, please contact Guideline Geor or your local Guideline Geo representative for advice.

System Malfunctions

Most malfunctions are power/data communications or user settings related. Before contacting your local Guideline Geo office or authorized dealer please follow these simple steps:

Check user settings	Enter the Measurement Parameters menu and check the settings for Acquisition Mode, Wheel Type, Point interval etc.
Check battery capacity	Connect the battery to the charger and switch on the charger at the electrical outlet. The light on the battery charger should be either yellow or green indicating an operative charge. If the indicator light is red, continue charging until the charging cycle is complete, i.e., indicator light turns green.
Check connectors	Disconnect and reconnect the battery pack on the GX antenna. If using the external battery bag, disconnect and reconnect the battery connector in the battery bag. Disconnect and reconnect both ends of the data cable between the antenna and the MALÅ GX Controller. Check the pulse encoder connector on the rear of the antenna. When disconnecting/reconnecting, check the connectors for dirt or foreign objects.
Check Wi-Fi	Remake the Wi-Fi Initiation via Wire option.
Restart MALÅ GX Controller and antenna	Turn off the MALÅ GX antenna and Controller, by first selecting <i>QUIT</i> from the on-screen menu options on the Controller, confirm the action by selecting <i>YES</i> , then push the power button on the Controller and release quickly. The red light will then stop blinking and the unit will also emit a click when turning off. Wait 10 seconds before switching on the Controller and antenna.

Note: If the Controller is not responding, turn the unit off by pushing the power switch.

Service and Repairs

To maintain maximum performance, the MALÅ GX should be regularly serviced. Contact Guideline Geo or your local Guideline Geo representative for more information on how to service your MALÅ GX system.

Technical Support

Guideline Geo is committed to providing exceptional product support. Our technical support representatives are available online to help you find answers to even the most challenging technical support issues. Our experienced support team works very closely with the development teams to ensure that every client receives the best possible support.

Technical support requests can be made directly from our website: www.guidelinegeo.com