



# **MIRA Compact Tow Hitch Carrier**

## **User Guide**



## Our Thanks...

Thank you for choosing Guideline Geo and MALÅ! The very core of our philosophy is to provide our users with great products, support, and services. Our team is committed to providing you with the most efficient and easy-to-use solutions with the capability to meet your needs for efficiency and productivity.

Whether this is your first MALÅ product, or addition to the MALÅ collection, we believe that small investment of your time to familiarize yourself with the product by reading this manual will be rewarded with a significant increase in productivity and satisfaction.

Please let us know about your use and experience of our products as well as the contents and usefulness of this manual. We're excited to be part of your journey!



Under copyright laws, this manual may not be copied, in whole or in part, without the written consent of Guideline Geo. Your rights to the software are governed by the accompanying software license agreement. The MALÅ logo is a trademark of Guideline Geo registered in Sweden and other countries.

The product described in this document is subject to continuous developments and improvements. All particulars of the product and its use contained in this document are given by Guideline Geo in good faith. However, all warranties implied or expressed, including but not limited to implied warranties or merchantability, or fitness for purpose, are excluded. This document is intended only to assist the reader in the use of the product, and every effort has been made to ensure that the information in this manual is accurate. Guideline Geo shall not be liable for any loss or damage arising from the use of any information in this document, or any error or omission of such information, or any incorrect use of the product. The operation and interpretations made based on the use of this product is the sole responsibility of the operator.

Guideline Geo, the MALÅ logo, are trademarks of Guideline Geo, registered in Sweden and other countries. Other companies and product names mentioned herein are trademarks of their respective companies. The mention of third-party products is for informational purposes only and constitutes neither an endorsement nor a recommendation. Guideline Geo assumes no responsibility with regard to the performance or use of these products.

Guideline Geo AB

[www.guidelinegeo.com](http://www.guidelinegeo.com)

# Table of content

<b>MIRA Compact Tow Hitch Carrier</b>	<b>5</b>
<b>Assembly</b>	<b>6</b>
At delivery	6
MIRA Compact Tow Hitch Carrier mounting at delivery	6
<b>Tow hitch carrier setup</b>	<b>8</b>
Select measurement mode	8
Measure tow ball height on the vehicle	8
Set the height-adjustment tower rotation	9
Further adjustments	10
MIRA Compact Tow Hitch Carrier mounting on to the vehicle	12
MALÅ MIRA Compact antenna box mount	13
<b>Other</b>	<b>15</b>
GNSS support arms	15
Wheel encoder	15
Transport mode	16
Skid skates	16
Support straps	17
Software	17
Accessories	17
Spare parts	18

# MALÅ MIRA Compact Tow Hitch Carrier

The MIRA Compact Tow Hitch Carrier is a carrier solution for the MALÅ MIRA Compact multichannel GPR system. This carrier is intended to be used behind an ATV (4-wheeler) or a car/pick-up when carrying out measurements on, for example, agricultural land or grass fields.

It is the user's responsibility to check what road regulations applies in the investigation area and during transport (for lights, reflective material, e.g.).



# Assembly

## At delivery

The MIRA Compact Tow Hitch Carrier is delivered on a pallet. Most parts of the carrier are preassembled; you only need to attach the hitch coupling and height adjustment tower.

The following items are included on the pallet:

- Hitch coupling
- Height adjustment tower
- Antenna carrier with cover
- Package with cables, bolts, and instruction to the hitch coupling
- Straps to stabilize the Tow Hitch Carrier. These are 4 meters long and can be used with different types of vehicles.

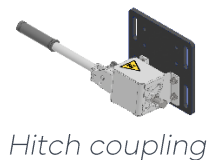

*Hitch coupling*

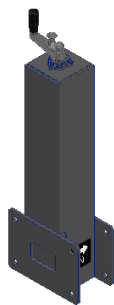

*Height adjustment tower*

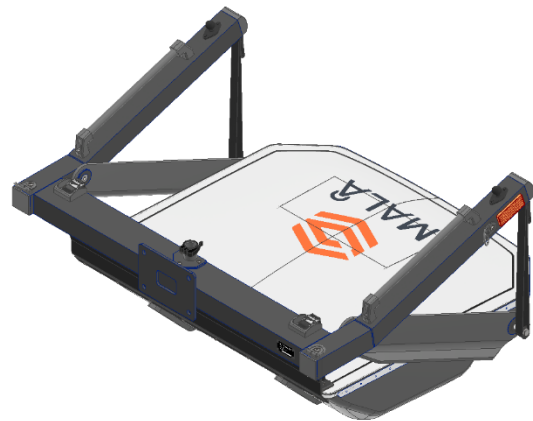

*Antenna carrier with cover*

**Note:** The height adjustment tower, hitch coupling locking arm and the extension arm are attached to the bottom of the pallet with screws.

## MIRA Compact Tow Hitch Carrier mounting at delivery

The MIRA Compact Tow Hitch Carrier can be used with different types of vehicles such as ATVs, cars or pick-up trucks. The height adjustment tower and the adjustable plate for the hitch coupling gives several options for a good set up with varying heights of the vehicle used. Please refer to the [Set the Height Adjustment](#) section for guidance on your setup.



*Car mount in measurement mode*



*Van mount in measurement mode*



*ATV mount in measurement mode*

# Tow Hitch Carrier setup

## Select measurement mode

Choose one of the following based on the surface you will investigate:

- Ground measurement — for surveys on soft/forgiving ground (e.g., grass, soil).
- Air measurement — for surveys over hard/abrasive surfaces (e.g., asphalt, concrete).

The choice between ground and air measurements determines the rotation of the height adjustment- tower used in step 3.

### GROUND MEASUREMENT



### AIR MEASUREMENT

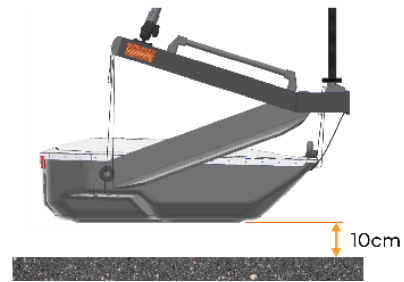

## Measure tow ball height on the vehicle

Measure from the ground to the center of the tow ball. Record this value in cm.

**Note:** Loading the tow ball helps compensate for suspension sag and yields a more accurate operating height.



Tow ball height  
(ground to center)

## Set the height adjustment tower rotation

Using the illustration below, select the rotation (e.g., A / B as marked) that corresponds to your measured tow ball height and the chosen measurement mode (Ground or Air). The arrow decal indicates the reference direction.

**Example:** Measured tow ball height = 30 cm, for **ground** measurement choose rotation B (the arrow decal facing the vehicle). With this rotation you will be able to lower the antenna using the adjustment tower.

**Note:** If there is an overlap, select Option B

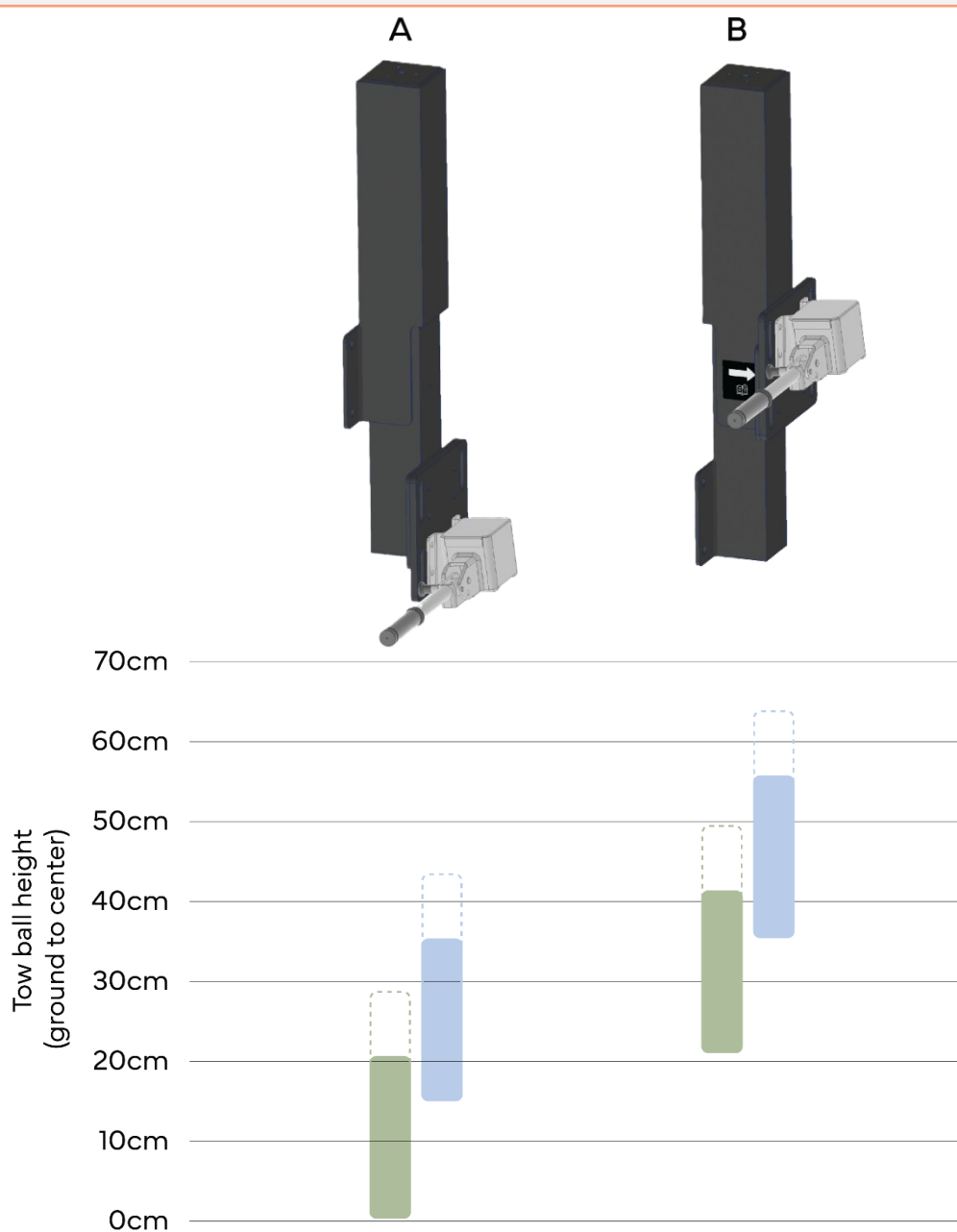

## Further adjustments

For additional adjustment of your setup, you can reposition the tow hitch coupling on its mounting plate. This changes the relative height/offset between the carrier and the vehicle and can help you achieve the target antenna height.

**Note:** Use Tow ball height Diagram to visualize how each hole/slot position affects the effective measurement height.

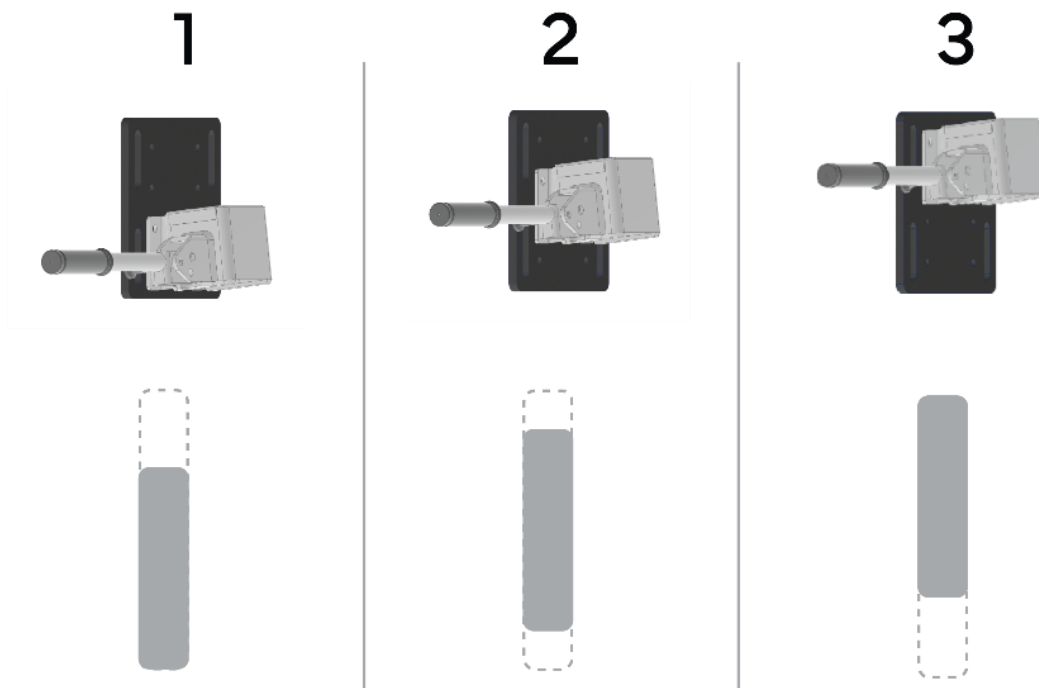

### Using the height adjustment tower

The antenna height can quickly be adjusted using the height adjustment tower.

1. Release the locking bolt  
Rotate the locking bolt until it stays in the open position.
2. Adjust the antenna height  
Turn the handle to raise or lower the antenna to the desired position.
3. Lock the locking bolt
4. Verify correct setup if needed  
If you are unable to adjust the antenna to the required height, refer to the *Tow Hitch Carrier setup* section to ensure your setup is correct for your current vehicle.

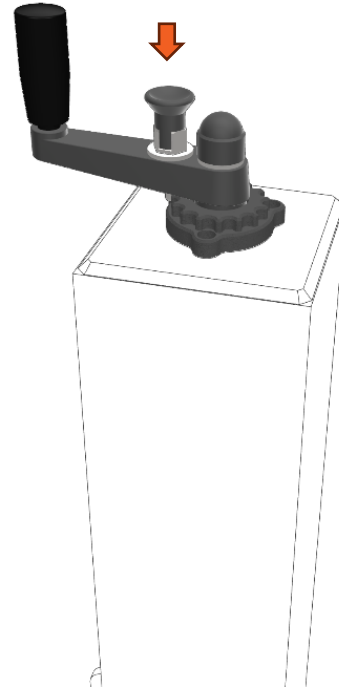

### Attachment without the height adjustment tower

In some cases, depending on the height of your tow ball, it may be possible to attach the antenna carrier directly to the hitch coupling without installing the height adjustment tower.

**Warning:** Attaching the antenna carrier directly to the hitch coupling will reduce system performance. Attaching without the tower will sacrifice either:

1. the floating range capability of the system, or
2. the ground clearance when in transport mode.

For best results, we recommend using the height adjustment tower whenever possible.

## MIRA Compact Tow Hitch Carrier mounting on to the vehicle

**Note:** For smooth and safe installation, we recommend that two people perform this task.

1. Prepare the hitch coupling.  
Disengage the locking pin on the hitch coupling, then lift the locking lever to fully open the hitch coupling.

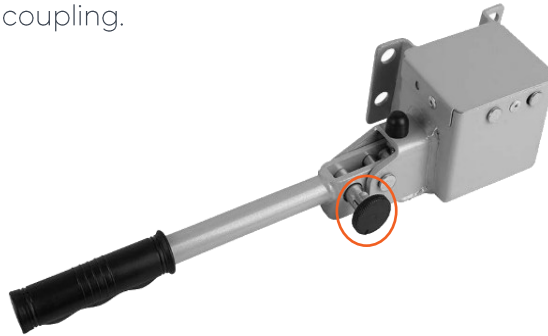

2. Mount the carrier.  
Lift the entire carrier over the tow ball and lock it in place using the hitch coupling lever. Ensure the locking pin is engaged before proceeding.

### Adjusting the clamping force

For optimal safety and stability, the clamping force of the hitch coupling may need to be adjusted depending on your tow ball.

- Please refer to the manufacturer's notes provided with the product for detailed instructions.
- Always confirm that the hitch coupling is firmly secured and that there is no excessive play before transporting the system.



## MALÅ MIRA Compact antenna box mount

- 1) Remove your MIRA Compact antenna box from the MIRA Compact frame. It is ok to leave the straps on the box. For further instructions see MIRA Compact *User Guide*.
- 2) Open the dirt cover of the MIRA Compact Tow Hitch Carrier and slide in the antenna box.
- 3) Mount the two straps (below the dirt cover) to make sure the antenna box is stable. See picture below.
- 4) Connect cables (communication cable to field computer and encoder cable to a pulse encoder, if this is used) and pull these through the cover. Ensure the cables are short enough to prevent them from reaching the ground, use the provided hook-and-loop straps.
- 5) Measurement mode:
  - a. Lower the front straps fully, they should be slack. The rubber mat will carry the load of the box in measurement mode providing the full flotation range.
  - b. Use the back straps to adjust the angle of attack. Make sure the antenna is in the air when doing this, if not adjust the antenna height using the height adjustment tower.
  - c. Adjust the final measurement height with the Height adjustment tower.
- 6) Start the MIRA Compact and close the cover.
- 7) Setup the GNSS, by using the GNSS support arms. See section *GNSS support arms*.
- 8) You are ready for measurements.

If needed, see *MIRA Controller* and *MIRA Compact User Guides* for more information on measurement settings.

**Note:** Remember to raise the antenna to Transport mode if moving to/from your measurement site.



*Two safety straps under the MIRA Compact Tow Hitch Carrier cover*

## Other

### GNSS support arms

For good GNSS reception use the GNSS support arms included in the MIRA Tow Hitch Carrier package.

The pole length can be adjusted to two different heights, using one or two 800 mm poles.

Make sure the GNSS pole is vertical, for best positioning precision.

Make sure to choose the correct GNSS offset for data collection in the MIRA Controller software. See *MALÅ Controller User Guide* for more information.

When using a cable connection, always secure the cables with the provided hook-and-loop ties. This prevents strain on the connectors and reduces the risk of damage during use or transport.



### Wheel encoder

The MALÅ MIRA Compact can be triggered without a wheel encoder using either time trig or MALÅ Motion Trig. MALÅ Motion Trig utilizes the movement of the internal GNSS to trigger the data collection, giving equidistant traces without encoder wheels being connected to the antenna.

If you are using the external MALÅ Pulse encoder kit, make sure to attach this firmly to one of the vehicle wheels and perform a wheel calibration in the MIRA Controller software. For more information, see *MIRA Controller User Guide*.



**Warning:** Always secure all cables with the provided hook-and-loop ties. Loose cables can get caught in the wheel during operation, which may cause equipment damage or personal injury.

**Note:** The MALÅ Pulse encoder kit is an accessory. Contact [sales@guidelinegeo.com](mailto:sales@guidelinegeo.com) for further information.

## Transport mode

To set the system in transport mode:

- 1) Pull the two front straps fully, use the two handles on the antenna box if needed. This will lift the front of the antenna box.
- 2) Pull the two rear straps fully, or so that the antenna sits level. This will lift the back of the antenna box
- 3) Lift the antenna box to its highest position using the height adjustment tower. This gives the highest ground clearance



*Example of transport mode (left) and measuring mode (right)*

## Skid skates

This unit is equipped with two skid skates mounted under the antenna box, serving as the antenna box wear protection. The skates are secured in place with screws through the antenna box.

The unit is shipped with two extra sets of skids as spares. We recommend that the customer always keeps at least one spare set available.

**Note:** Before each measurement session, **ALWAYS** inspect the condition of the skid skates to ensure the antenna box remains protected. This is particularly important when operating the product on abrasive surfaces (as e.g. asphalt), where wear occurs more quickly.

## Support straps

When using the unit on an ATV, it is recommended to use the support straps provided. These prevent the carrier from rotating on the tow ball due to the higher rotational forces caused by quick turning.

The carrier frame is equipped with four attachment points for the support straps. Select the attachment points that are best suited to your current setup. Ensure that the straps are tightened securely before operation.

**Note:** Proper use of support straps increases stability and reduces wear on both the carrier and the ATV.



*Front and rear attachment points*

## Software

Make sure to always use the latest version of the acquisition software [MIRA Controller](http://www.guidelinegeo.com) available for download from [www.guidelinegeo.com](http://www.guidelinegeo.com).

## Accessories

To the MALÅ Tow Hitch Carrier you can add the following accessories:

- Extension arm for hitch. This is needed when the hitch is very close to the back of the vehicle.
- Pulse encoder kit. This can be connected to almost any wheel, for distance trig, if not using MALÅ Motion Trig.
- GNSS extender cable, 7 meters.
- Serial-USB converter, if your field computer does not have a serial port.



## Spare parts

If you need spare parts, please contact [support@guidelinegeo.com](mailto:support@guidelinegeo.com) and include your product model, serial number, parts required (with quantities), shipping address, and a contact phone number.

For quicker handling please also include a picture and a description of the part to be replaced.